



KOROK®

INTERTENANCY APARTMENT SYSTEMS



JUNE 2026
Version 22

KOROK 



KOROK®

INTERTENANCY APARTMENT SYSTEMS

SECURE, QUIET, FLEXIBLE.

Multi-unit construction projects, such as apartments, call for well-tested technology that's simple to install. KOROK® Intertency wall offers the benefits of proven fire and acoustic performance, and the security of a solid wall design.

SECURE

KOROK® panels consist of a steel shell filled with aerated concrete. Having a solid wall provides peace of mind to occupants in the knowledge that they are physically separated from neighbouring dwellings.

QUIET

KOROK® panels offer superior mass over traditional timber and plasterboard or equivalent systems resulting in enhanced sound attenuation, particularly in the more invasive lower frequencies. This means that residents are comfortable in their own space without the intrusion of noise from other dwellings.

FLEXIBLE

Because KOROK® panels provide all the fire protection you need, you can run electrical and plumbing services on the intertenancy wall without the need for special penetration seals around each pipe or light switch. This allows you the flexibility of placing a TV and kitchen where you want, and the ability to hang fixtures on the wall without compromising the fire and acoustic resistance of the Intertency wall.

This manual has been developed using recognised Australian and New Zealand Standards together with sound engineering principles substantiated through BRANZ.

This manual in no way supersedes the requirements of any Statutory Authority or New Zealand Building Code but is rather a guide to the performance of KOROK® under certain loading conditions.

The manual provides builders, engineers, designers and architects with a user-friendly format for installing and designing KOROK® for non-load bearing applications.

In brief, KOROK® has:

- Fire-rated systems ranging from 30 minutes to 240 minutes.
- Acoustic systems ranging from STC 36 to STC 76.
- Panel dimensions of 250mm wide, in lengths up to 9.3 metres.
- Panels that weigh (nominally) 10.2kg per lineal metre.
- Panels available in galvanised or colour steel.

Typical Applications are:

- Dividing and boundary walls for sheds, factories and warehouses.
- Cinema walls.
- Intertenancy walls for apartments, terraced housing, hotels and retirement complexes.
- Lift shaft and duct walls.
- Acoustic barriers.

Due to its unique composition, KOROK® provides exceptional fire resistance over a long period of time.

However, to achieve the stated fire resistance ratings, it is critically important to adhere strictly to the design, installation and construction details otherwise the fire resistance rating may be degraded.

KOROK® panels have been tested and appraised by the Building Research Association of New Zealand (BRANZ). In some cases, a fire resistance rating has been based on an appraisal from the same organisation.

Where specific acoustic control performance is required, KOROK® can provide a number of proven, acoustic-rated wall systems, or can assist in developing a fully customised solution.



CONTENTS

INTRODUCTION	5	Last panel.....	46
Acoustic performance.....	5	Table 3 - Fastenings.....	47
Fire performance.....	5	C-track.....	47
100% reusable, minimum waste.....	5	Deflection C-track details.....	47
Use only the current specification.....	6	Final check.....	49
Beware of substitutions.....	6	Head track protection.....	50
Purpose.....	6	Deflection C-track details.....	50
Scope of Use.....	6	TABLE 4 - KOROK® FASTENERS SPACINGS	51
Definitions.....	6	PANEL PROPERTIES	52
Deflection C-track details.....	6	KOROK® panels.....	52
Transport.....	7	Loading combinations.....	52
Handling and storage.....	7	General design notes.....	52
Cleaning.....	7	Manufacturers' documents.....	52
Strippable film.....	7	KOROK® PANEL PROPERTIES: 78MM	53
Cutting of KOROK® panels.....	7	Vertical span walls.....	53
Installation.....	7	Horizontal span walls.....	53
WHY USE KIR (KOROK® INTERTENANCY RESIDENTIAL) SYSTEMS?	8	Thermal resistance.....	53
Designer / Specifier.....	8	Definitions.....	53
Constructor.....	8	Use of tables.....	53
KOROK® INTERTENANCY APARTMENT SYSTEMS	9	Deflection C-track details.....	53
Table 1 - KIR (KOROK® INTERTENANCY RESIDENTIAL) SYSTEMS SUMMARY TABLE.....	9	Supporting structures.....	53
KIR01 FRR -/60/60.....	11	Installation note.....	53
KIR03 FRR -/60/60.....	13	Table 5 - Shear strength per fastener for the following connections.....	54
KIR04 FRR -/60/60.....	15	Table 6 - Horizontal span.....	54
KIR05 FRR -/60/60.....	17	Table 7 - Vertical span.....	54
KIR09 FRR -/60/60.....	19	KOROK® PANEL PROPERTIES: 51MM	55
KIR14 FRR -/60/60.....	21	Vertical span walls.....	55
KIR15 FRR -/120/120.....	23	Horizontal span walls.....	55
KIR17 FRR -/120/120.....	25	Definitions.....	55
KIR20 FRR -/120/120.....	27	Use of tables.....	55
KIR21 FRR -/120/120.....	29	Deflection C-track details.....	55
Table 2 - KIM (KOROK® INTERTENANCY MULTILEVEL) SYSTEMS SUMMARY TABLE.....	31	Supporting structures.....	55
KIM01 FRR -/60/60.....	32	Installation note.....	55
KIM02 FRR -/60/60.....	33	Table 8 - Shear strength per fastener for the following connections.....	56
KIM03 FRR -/60/60.....	34	Table 9 - Horizontal span.....	56
KIM04 FRR -/60/60.....	35	Table 10 - Vertical span.....	56
KIM05 FRR -/60/60.....	36	INTERTENANCY APARTMENT DEFLECTION HEAD DETAILS	57
KIM06 FRR -/120/120.....	37	INTERTENANCY APARTMENT BRACKET DETAIL	59
KIM07 FRR -/120/120.....	38	KOROK® COMPONENTS SUMMARY	60
KIM08 FRR -/60/60.....	39		
KIM09 FRR -/60/60.....	40		
KIM12 FRR -/60/60.....	41		
KIM13 FRR -/60/60.....	42		
INTERTENANCY APARTMENT SYSTEMS INSTALLATION	44		
Vertical installation.....	44		

INTRODUCTION

SUPERIOR FIRE AND ACOUSTIC PERFORMANCE WITH CLIP-TOGETHER SIMPLICITY

- BRANZ appraised
- Roll formed galvanised steel or colour steel outer shell
- Lightweight with an aerated concrete core
- Fire ratings up to -/240/240
- Acoustic ratings up to STC 76
- Panels interlock with clip-together simplicity for rapid installation
- Can be dismantled and reassembled to accommodate changing requirements
- Can be installed horizontally or vertically

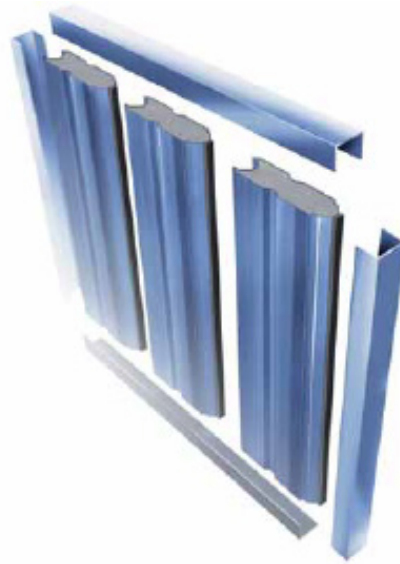

When acoustic and fire regulations demand a high performance, no-risk solution, KOROK® will exceed New Zealand Building Code requirements for internal and external non-load bearing walls simply and cost effectively.

Exceptionally strong yet lightweight, the interlocking panels can be easily erected by a small crew, making KOROK® much faster to install than conventional wall systems.

Construction using KOROK® allows a building to be made weather resistant much earlier in the construction cycle, allowing internal work and finishing to be started sooner.

ACOUSTIC PERFORMANCE

KOROK®'s inherent mass and interlocking design gives it outstanding acoustic reduction properties making it highly suitable in buildings where acoustic performance is critical, such as cinemas, lecture theatres, apartments, recording studios and industrial/commercial intertenancy situations.

The unique interlocking design eliminates the risk of sound 'leaks' between panels, and makes installation much faster and more simple than traditional systems.

FIRE PERFORMANCE

KOROK® delivers proven two-way fire resistance over a long period of time. KOROK® has been tested and appraised by the Building Research Association of New Zealand (BRANZ).

100% REUSABLE, MINIMUM WASTE

KOROK® is manufactured in New Zealand and offers unique benefits in terms of sustainability and environmental performance:

- Walls can be reused by simply dismantling the panels and reinstalling them in another location.
- The raw components (steel and concrete) are 100% recyclable.
- Panels are custom manufactured to size, minimising waste at the factory and on the construction site.
- DECLARE - KOROK® has Declare Certification for our panels, the most accessed sustainability certification in the building industry <https://declare.living-future.org/products/korok-panel>. See page 63.

INTRODUCTION

USE ONLY THE CURRENT SPECIFICATION

This publication may be superseded by a new publication. KOROK® Building Systems NZ Ltd accepts no liability for reliance upon publications that have been superseded. If you are unsure whether this is the current publication, visit www.korok.com or call 0800 773 777.

This may be freely copied (in full) or reproduced (in full) and is available by contacting us at KOROK® on 0800 773 777 or info@korok.com, or from www.korok.com

BEWARE OF SUBSTITUTIONS

All KOROK® systems have been designed and tested to ensure they are suitable for New Zealand conditions and provide specific resistance to fire and acoustic transmission.

As such, only tested KOROK® panels and components can be used in the construction of each KOROK® system, ensuring that the finished wall will meet its performance specification.

PURPOSE

KOROK® provide intertenancy systems that physically separate spaces, providing secure divisional walls and intertenancy sound and fire transmission resistance.

KOROK® supplies separate systems for terraced housing and apartment intertenancy walls. Please ensure that the system selected is identified as being appropriate for the location it is being installed in. For terraced housing intertenancy walls please see our publication [KOROK® Intertenancy Terraced Housing Systems Manual](#).

SCOPE OF USE

New Zealand Building Code (NZBC) compliance

The NZBC sets out both the legal minimum sound transmission between tenancies (Clause G6) and minimum levels of fire resistance (Clauses C3 and C6). The KOROK® Intertenancy Systems Manual provides guidance on the specification and construction of systems that will both meet and exceed those minimum levels. However, designers should consider the comfort of occupants when selecting a system that will satisfy the occupants' expectations when using the space rather than the minimum required by law.

NZBC Clause B1 – Structure

The KOROK® Systems meet the requirements for loads arising from self-weight, earthquake, wind, impact and creep and shrinkage.

NZBC Clause B2 – Durability

Under normal conditions of dry internal use, KOROK® Intertenancy Systems have a serviceable life in excess of

50 years and satisfy the requirements of NZBC Clause B2 – Durability.

NZBC Clauses C3 - Fire affecting areas beyond the source

KOROK® Intertenancy Systems can be used to provide passive fire protection in accordance with the requirements of NZBC Clause 3 – Spread of fire

NZBC Clause C6 - Structural Stability

Compliance with (NZBC) Clause C6 'Structural Stability'.

In order to satisfy the requirements of the New Zealand Building Code (Clause 6) relating to 'structural stability', designers must ensure that KOROK® elements are supported by primary elements that have at least the same fire rating as the KOROK® system that is used.

Where the primary elements supporting the KOROK® system are outside the fire cell, there is no requirement to apply the same FRR as the KOROK® system. Notwithstanding, post fire stability requirements of the NZBC must also be satisfied.

NZBC Clause G6 – Airborne and Impact Sound

KOROK® Intertenancy Systems both meet and exceed the minimum requirements outlined in NZBC Clause G6. Consideration should be given to both the minimum requirements and the comfort of occupants.

DEFINITIONS

STC

Sound Transmission Class is derived from an ASTM standard test procedure which rates the airborne sound transmission loss through building elements such as walls and ceilings. dB loss is measured at a 1/3 octave range between 125Hz and 4000Hz. The minimum requirement for residential intertenancy is STC 55.

FRR

Fire Resistance Rating is derived from a laboratory furnace test which gives a value in minutes for structural adequacy, integrity, and insulation. Depending on design, all three may not be relevant to the building element.

DEFLECTION C-TRACK DETAILS

Dead and live loads can cause significant deflection in some structures.

KOROK® can provide deflection C-track details where deflection loadings are considered.

Contact your KOROK® representative on 0800 773 777 for a solution specific to your project.

INTRODUCTION

TRANSPORT

Generally the lengths of KOROK® panel are delivered to site by long trailers and articulated trucks. Therefore, access to and on building sites must be adequate to accommodate these types of vehicles.

Off-loading and site storage or craning onto site is the responsibility of the client and suitable arrangements should be made prior to delivery.

KOROK® products are packed and protected against damage during delivery but care must be exercised during unloading.

Lengths must be adequately supported during unloading and where packs are broken and panels lifted by hand, care must be taken not to slide or drag the panel and scrape the finished surfaces of the product.

HANDLING AND STORAGE

KOROK® panels must be stored under clean, dry and ventilated conditions.

Where it is necessary for KOROK® panels to be stored onsite, they should be placed away from the building operations, if possible, in the order in which they will be fixed.

Storage should provide a firm and dry base, protected from the weather, accidental damage and moisture.

Store KOROK® panels onsite flat or in their pallets and ensure that KOROK® panels are dry prior to installation.

The panels should be stored on bearers no more than 2000mm apart. Stack heights are limited to 8 pallets.

Adequate cover must be provided and water must not lie on or between the panel surfaces, which will cause staining and degradation of the surface coatings.

If pallets become wet, the KOROK® panels should without delay be separated, wiped with a clean cloth and stacked so that the circulation of air will complete the drying process.

Handle KOROK® panels carefully prior to installation. Avoid knocks, bumps and scratches, which may lead to maintenance issues later.

CLEANING

At the completion of the job and at the finish of each day's work, it is essential that the completed area be thoroughly cleaned of all swarf, rivet stems, nails, drillings and screws, etc. normally associated with the installation of metal panels.

STRIPPABLE FILM

KOROK® panels may be coated with a plastic film to provide protection during handling and transportation. This film has a very short life when exposed to exterior conditions and must be removed immediately after installation.

It must not be left lying in the sun or at the site for more than a few hours. Failure to remove the film will lead to difficulties later with its removal.

CUTTING OF KOROK® PANELS

It's recommended that KOROK® panels are cut using a Hilti DCH300 Electric Concrete Cutter with dust removal system. Hot swarf should not be allowed to contact pre-painted or galvanized sheet material. Any grinding, welding or drillings carried out above the wall level should be done with the panels appropriately covered to avoid swarf contact.

Failure to do so will result in unsightly staining of the surface as the metal particles rust or oxidise.

INSTALLATION

Specific design advice should be sought where KOROK® is to be subject to point loads or other distributed loading other than wind.

Ensure connections between KOROK® panels are properly made.

Ensure connections of KOROK® panels to the structure are adequate.

Why use KIR (KOROK® intertenancy residential) systems?



DESIGNER / SPECIFIER

- A wide range of systems / build-ups.
- Manufactured to order, reducing waste.
- Easy configuration.
- All-in-one fire rating.
- High performance noise control.
- Secure.
- Straightforward design and detailing.
- Straightforward wall type transitions through intertenancy, hallways, risers, lifts, stairs, and plant areas.
- Tested in New Zealand for NZBC compliance.
- Straightforward deflection head details.
- Straightforward passive fire penetration details.
- No requirement for fire-rated GPOs and switches.
- Reduction in linings.

CONSTRUCTOR

- Manufactured to order - less onsite waste, saving on waste disposal costs, less cutting onsite.
- Early installation - improved program times.
- Non weather dependent - improved program.
- Program continuity.
- Small crew to install.
- Lightweight and easy to handle.
- Single-sided fixing - ease of installation.
- Early inspection - improved program.
- Significantly less work in the ceiling plenum - labour and material costs savings, improved program.
- Straightforward deflection head details - labour and material costs savings.
- Straightforward passive fire penetration details - cost savings.
- Reduction in linings - less waste, more floor space available, fewer crane lifts, improved program.

KOROK® INTERTENANCY APARTMENT SYSTEMS

TABLE 1 - KIR (KOROK® INTERTENANCY RESIDENTIAL) SYSTEMS SUMMARY TABLE

SPEC. CODE	STC	FRR	WALL THICKNESS*	FRAME	CAVITY	SYSTEM SUMMARY	PAGE
KIR01	58	-/60/60	194mm	64mm Steel frame one side 28mm Furring channel on direct fix clips the other	Minimum 20mm	KOROK® 51mm panels (600 kg/m ³ density) + 1 layer 13mm GIB® Standard plasterboard or equivalent each side**	11
KIR03	59	-/60/60	167mm	28mm Furring channel on resilient mounts each side	N/A	KOROK® 51mm panels (600 kg/m ³ density) + 1 layer 13mm GIB® Noiseline® or equivalent each side**	13
KIR04	59	-/60/60	161mm	64mm Steel frame one side	Minimum 20mm	KOROK® 51mm panels (600 kg/m ³ density) + 1 layer 13mm GIB® Standard plasterboard or equivalent each side**	15
KIR05	68	-/60/60	240mm	64mm Steel frame each side	Minimum 86mm between the framing. Framing not to touch KOROK® panel.	KOROK® 51mm panels (600 kg/m ³ density) + 1 layer 13mm GIB® Standard plasterboard or equivalent each side**	17
KIR09	60	-/60/60	177mm	28mm Furring channel on BETAGRIP® Clips each side	N/A	KOROK® 51mm panels (600 kg/m ³ density) + 1 layer 13mm GIB® Noiseline® or equivalent each side**	19
KIR14	55	-/60/60	109mm	28mm Furring channel on resilient mounts one side	N/A	KOROK® 51mm panels (600 kg/m ³ density) + 1 layer 13mm GIB® Noiseline plasterboard or equivalent one side**	21
KIR15	56	-/120/120	141mm	28mm Furring channel on BETAGRIP® Clips one side	N/A	KOROK® 78mm panels (400 kg/m ³ density) + 1 layer 13mm GIB® Noiseline® or equivalent one side**	23
KIR17	61	-/120/120	204mm	28mm Furring channel on BETAGRIP® Clips each side	N/A	KOROK® 78mm panels (400 kg/m ³ density) + 1 layer 13mm GIB® Noiseline® or equivalent each side**	25
KIR20	60	-/120/120	233mm	64mm Steel frame one side, 28mm Furring channel on BETAGRIP® Clips the other side	Minimum 15mm	KOROK® 78mm panels (400 kg/m ³ density) + 1 layer 13mm GIB® Noiseline® or equivalent one side + 1 layer 13mm GIB® Standard plasterboard or equivalent the other side**	27
KIR21	69	-/120/120	262mm	64mm Steel frame each side	Minimum 108mm between the framing. Framing not to touch KOROK® panel.	KOROK® 78mm panels (400 kg/m ³ density) + 1 layer 13mm GIB® Noiseline® or equivalent each side**	29

*Nominal thickness

**Acoustic insulation for each system is as per specification sheet

DEFLECTION C-TRACK DETAILS

Dead and live loads can cause significant deflection in some structures.

KOROK® can provide deflection C-track details where deflection loadings are considered.

KOROK® INTERTENANCY APARTMENT SYSTEMS

TABLE 1 - KIR (KOROK® INTERTENANCY RESIDENTIAL) SYSTEMS SUMMARY TABLE (CONT.)

For further information on the following systems, see our website <https://korok.com/systems/korok-apartment-intertenancy-walls/>

SPEC. CODE	STC	FRR	WALL THICKNESS*	FRAME	CAVITY	SYSTEM SUMMARY
KIR02	57	-/60/60	122mm	28mm Furring channel on resilient mounts one side	N/A	KOROK® 51mm panels (600 kg/m ³ density) + 1 layer 13mm GIB Noiseline® or equivalent each side**
KIR06	59	-/120/120	188mm	64mm steel frame one side	Minimum 20mm	KOROK® 78mm panels (400 kg/m ³ density) + 1 layer 13mm GIB Noiseline® or equivalent one side + 1 layer 13mm GIB® Standard plasterboard or equivalent other side**
KIR07	59	-/120/120	188mm	64mm steel frame one side	Minimum 20mm	KOROK® 78mm panels (400 kg/m ³ density) + 1 layer 13mm GIB® Standard plasterboard or equivalent each side**
KIR08	61	-/60/60	181mm	64mm steel frame one side 16mm Furring channel on direct fix clips the other	Minimum 20mm	KOROK® 51mm panels (600 kg/m ³ density) + 1 layer 13mm GIB Noiseline® or equivalent each side**
KIR16	57	-/120/120	154mm	28mm Furring channel on BETAGRIP® Clips one side	N/A	KOROK® 78mm panels (400 kg/m ³ density) + 1 layer 13mm GIB Noiseline® or equivalent each side**
KIR18	58	-/120/120	204mm	28mm Furring channel on BETAGRIP® Clips each side	N/A	KOROK® 78mm panels (400 kg/m ³ density) + 1 layer 13mm GIB Noiseline® or equivalent one side + 1 layer 13mm GIB® Standard plasterboard or equivalent other side**
KIR19	55	-/120/120	204mm	28mm Furring channel on BETAGRIP® Clips each side	N/A	KOROK® 78mm panels (400 kg/m ³ density) + 1 layer 13mm GIB® Standard plasterboard or equivalent each side**

*Nominal thickness

**Acoustic insulation for each system is as per specification sheet

DEFLECTION C-TRACK DETAILS

Dead and live loads can cause significant deflection in some structures.

KOROK® can provide deflection C-track details where deflection loadings are considered.

KIRO1 FRR -/60/60

SPEC. CODE	STC	FRR	WALL THICKNESS*	FRAME	CAVITY	SYSTEM SUMMARY
KIRO1	58	-/60/60	194mm	64mm Steel frame one side. 28mm Furring channel on direct fix clips the other	Minimum 20mm	KOROK® 51mm panels (600 kg/m ³ density) + 1 layer 13mm GIB® Standard plasterboard or equivalent each side

KOROK® PANEL

KOROK® 51mm panels are located in KOROK® C-track 60mm high x 51mm wide x 1.15B.M.T. The KOROK® C-track is fixed to the structure at 400mm centres max, and bedded on a bead of fire-rated sealant. KOROK® panels must not exceed 5 metres in height.

FRAMING

64mm x 34mm x 0.55B.M.T. steel studs, friction fitted into C-Section track one side.

Allow a minimum 20mm gap between the framing and the KOROK® panel.

28mm Furring channel at 600mm maximum centres mounted on direct fix clips on the other.

Framing must be installed as per manufacturer's instructions.

ACOUSTIC INSULATION

Acoustic insulation must be either Greenstuf Sound Solution® Plus 75 or Pink® Batts® R1.8 or equivalent within the steel stud side and R0.5 GreenStuf® Masonry Wall Blanket or equivalent on the Furring channel side.

*Nominal thickness

Or omitting the insulation fixed to the KOROK® wall above ceiling height and laying a minimum R1.8 insulation over the ceiling.

LINING

Frames are lined to ceiling height with 1 layer of 13mm GIB® Standard plasterboard or equivalent on each side, fixed vertically with joints over framing one side and on Furring channels at 600mm maximum centres on the other.

Plasterboard linings are installed to the manufacturer's specification. Joints must be stopped.

SEALANT

Beads of fire-rated sealant are required around the perimeter of the KOROK® system.

Refer to the installation section of this publication for more information on sealant application.

Refer to the KOROK® Components Summary for approved sealants.

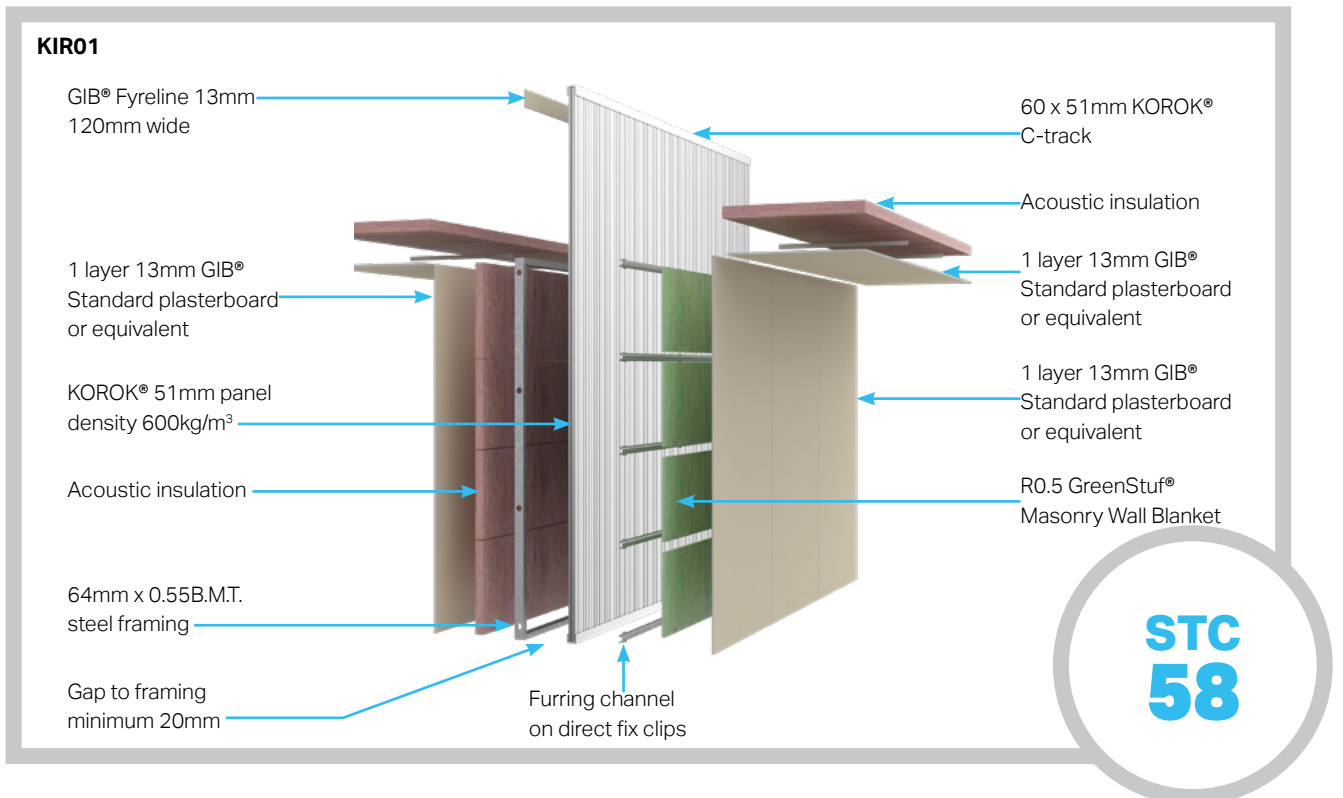

KIR01 FRR -/60/60

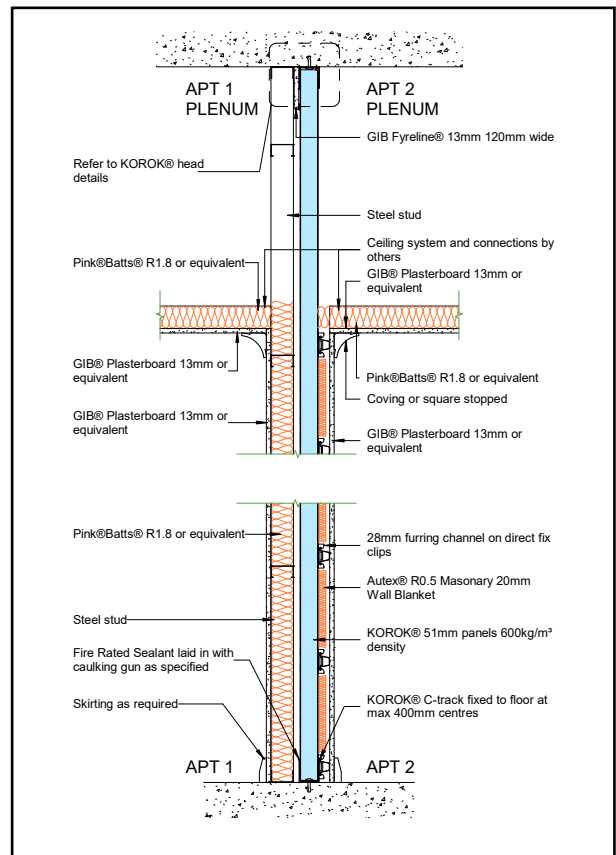
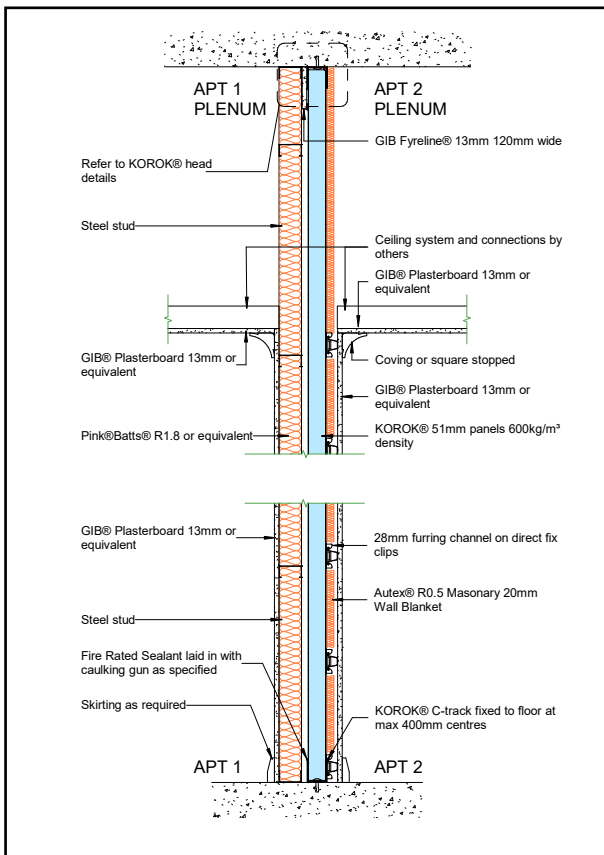
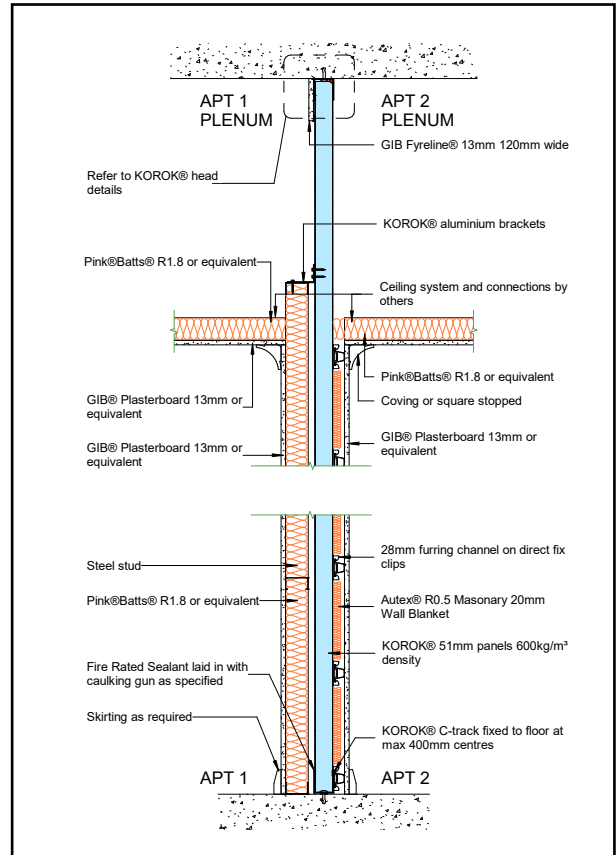
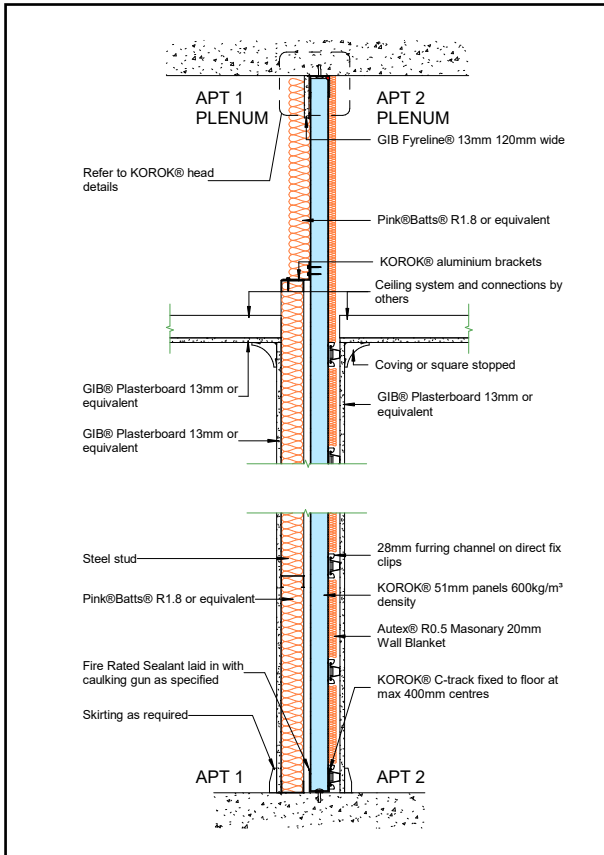

KIRO3 FRR -/60/60

SPEC. CODE	STC	FRR	WALL THICKNESS*	FRAME	CAVITY	SYSTEM SUMMARY
KIRO3	59	-/60/60	167mm	28mm Furring channel on resilient mounts each side	N/A	KOROK® 51mm panels (600 kg/m ³ density) + 1 layer 13mm GIB Noiseline® or equivalent each side

*Nominal thickness

KOROK® PANEL

KOROK® 51mm panels are located in KOROK® C-track 60mm high x 51mm wide x 1.15B.M.T. The KOROK® C-track is fixed to the structure at 400mm centres max, and bedded on a bead of fire-rated sealant. KOROK® panels must not exceed 5 metres in height.

FRAMING

28mm Furring channel at 600mm maximum centres one side mounted on ST001 Resilient Mounts fixed to KOROK® panel joints at 1000mm centres.

Framing must be installed as per manufacturer's instructions.

ACOUSTIC INSULATION

Acoustic insulation must be R1.3 GreenStuf® Masonry Wall Blanket or equivalent each side.

Or omitting the insulation fixed to the KOROK® wall above ceiling height and laying a minimum R1.8 insulation over the ceiling.

LINING

1 layer of 13mm GIB Noiseline® or equivalent on each side fixed vertically to ceiling height.

Plasterboard linings are installed to the manufacturer's specification. Joints must be stopped.

SEALANT

Beads of fire-rated sealant are required around the perimeter of the KOROK® system.

Refer to the installation section of this publication for more information on sealant application.

Refer to the KOROK® Components Summary for approved sealants.

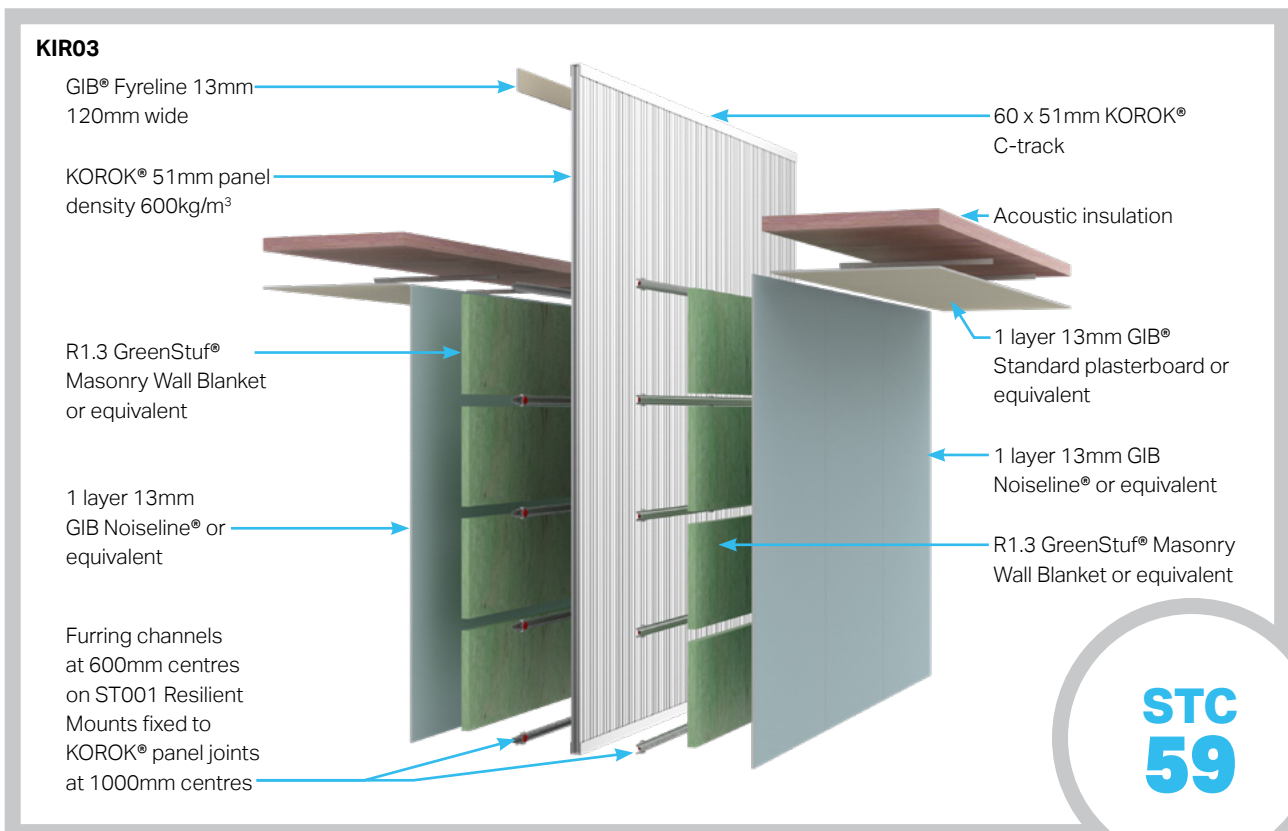

KIRO3 FRR -/60/60

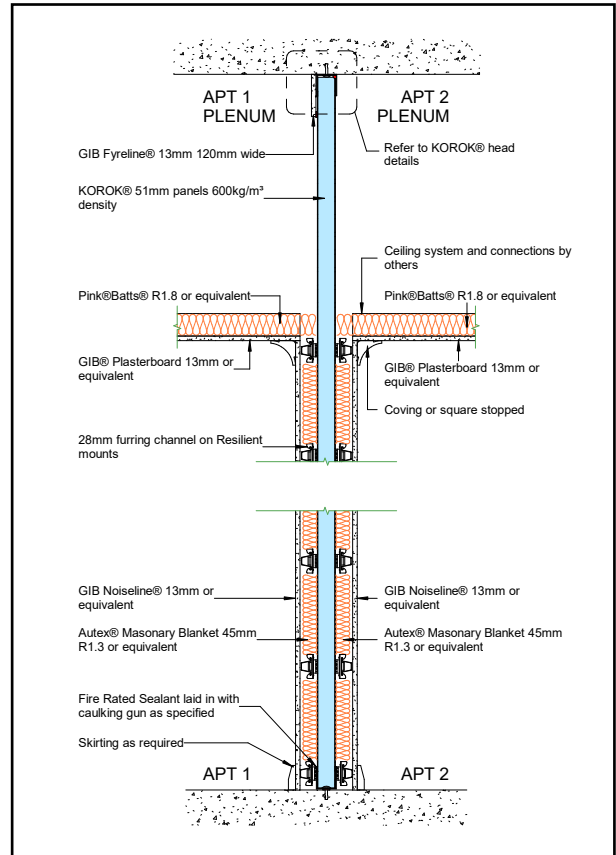
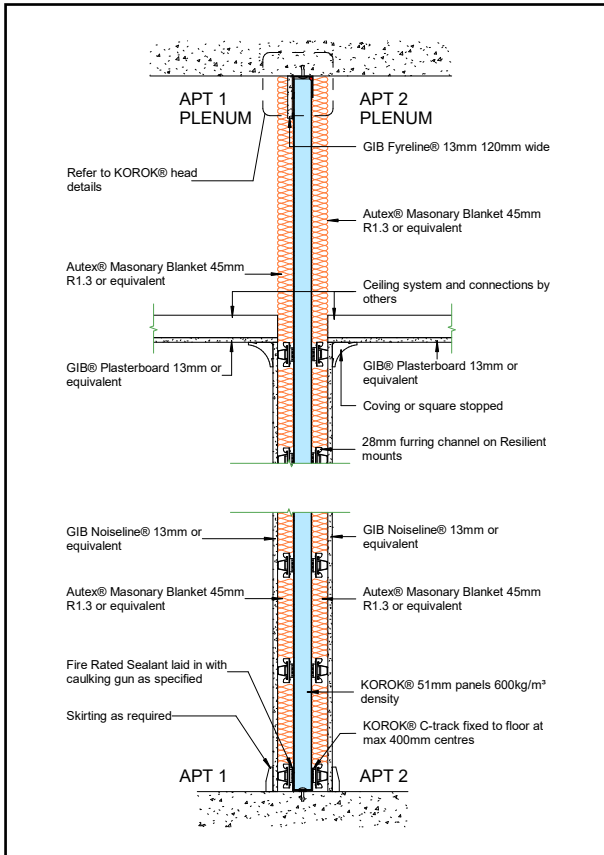

KIRO4 FRR -/60/60

SPEC. CODE	STC	FRR	WALL THICKNESS*	FRAME	CAVITY	SYSTEM SUMMARY
KIRO4	59	-/60/60	161mm	64mm Steel frame one side	Minimum 20mm	KOROK® 51mm panels (600 kg/m ³ density) + 1 layer 13mm GIB® Standard plasterboard or equivalent each side

*Nominal thickness

KOROK® PANEL

KOROK® 51mm panels are located in KOROK® C-track 60mm high x 51mm wide x 1.15B.M.T. The KOROK® C-track is fixed to the structure at 400mm centres max, and bedded on a bead of fire-rated sealant. KOROK® panels must not exceed 5 metres in height.

FRAMING

64mm x 34mm x 0.55B.M.T. steel studs, friction fitted into C-Section track 64mm x 30mm x 0.55B.M.T.

Allow a minimum 20mm gap between the framing and the KOROK® panel.

Framing must be installed as per manufacturer's instructions.

ACOUSTIC INSULATION

Acoustic insulation must be either Greenstuf Sound Solution® Plus 75 or Pink® Batts® R1.8 or equivalent within the steel stud side.

Or omitting the insulation fixed to the KOROK® wall above ceiling height and laying a minimum R1.8 insulation over the ceiling.

LINING

1 layer of 13mm GIB® Standard plasterboard or equivalent on each side fixed vertically with joints over framing one side and direct-fixed the other to ceiling height.

Plasterboard linings are installed to the manufacturer's specification. Joints must be stopped.

SEALANT

Beads of fire-rated sealant are required around the perimeter of the KOROK® system.

Refer to the installation section of this publication for more information on sealant application.

Refer to the KOROK® Components Summary for approved sealants.

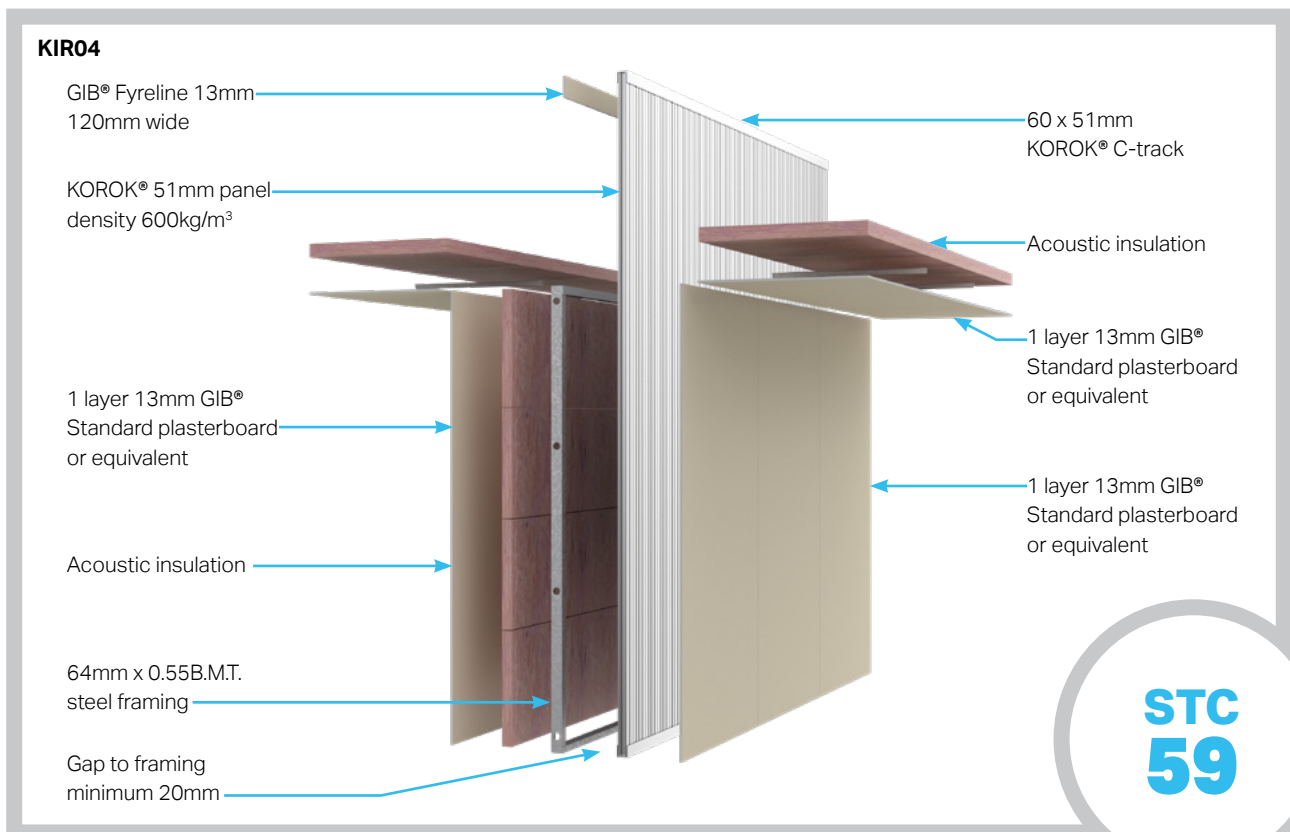

STC 59

KIRO4 FRR -/60/60

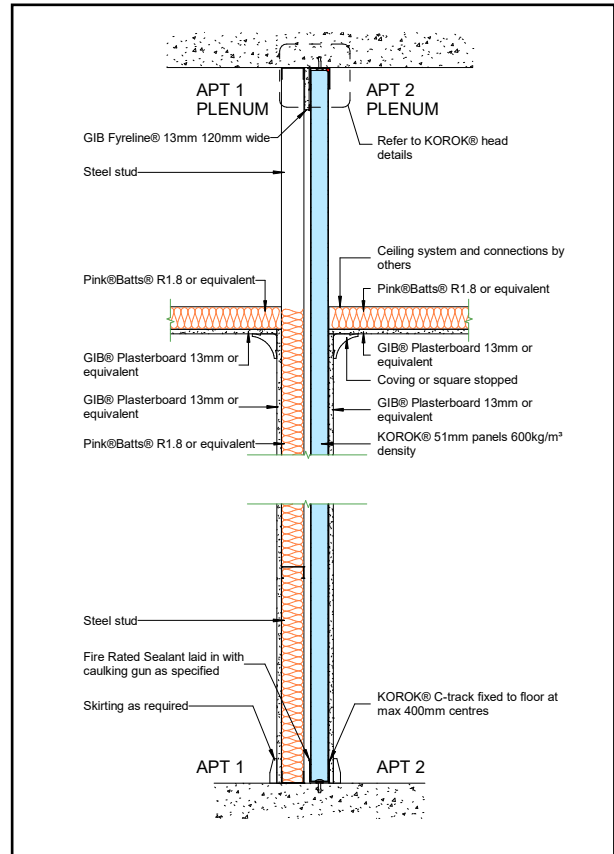
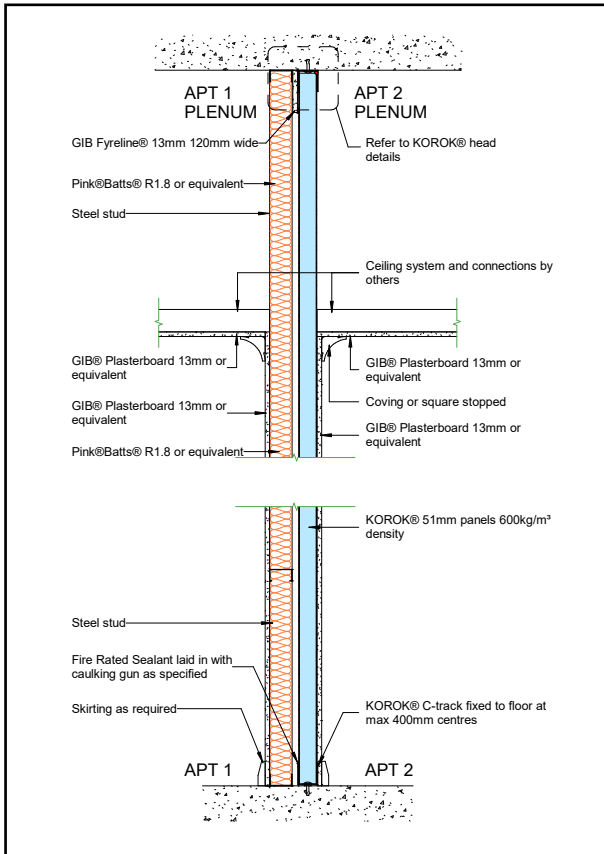
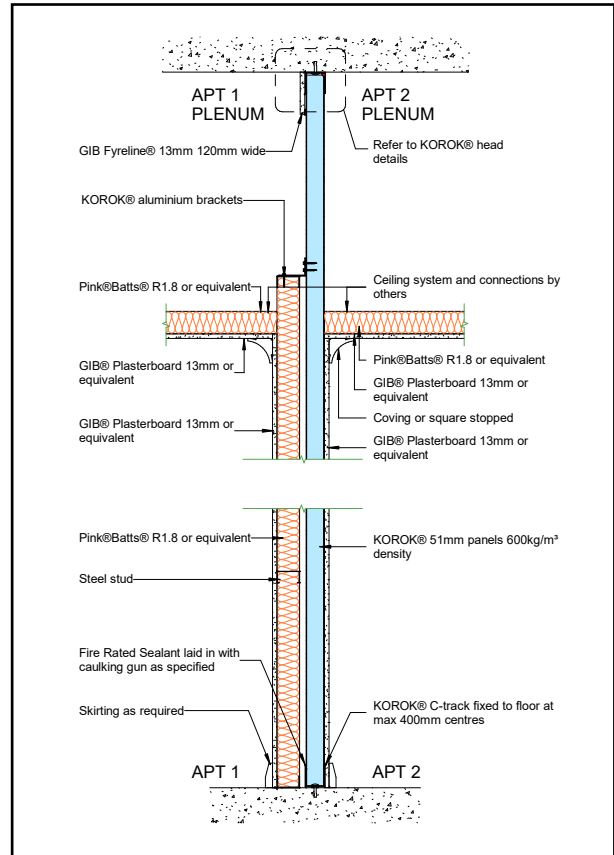
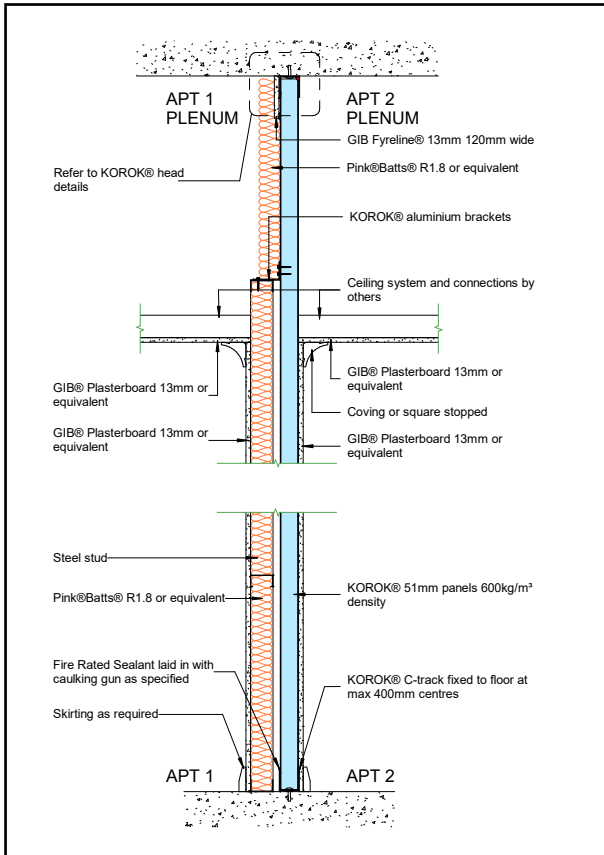

KIRO5 FRR -/60/60

SPEC. CODE	STC	FRR	WALL THICKNESS*	FRAME	CAVITY	SYSTEM SUMMARY
KIRO5	68	-/60/60	240mm	64mm Steel frame each side	Minimum 86mm overall between the framing. Framing not to touch KOROK® panel	KOROK® 51mm panels (600 kg/m ³ density) + 1 layer 13mm GIB® Standard plasterboard or equivalent each side

*Nominal thickness

KOROK® PANEL

KOROK® 51mm panels are located in KOROK® C-track 60mm high x 51mm wide x 1.15B.M.T. The KOROK® C-track is fixed to the structure at 400mm centres max, and bedded on a bead of fire-rated sealant. KOROK® panels must not exceed 5 metres in height.

FRAMING

64mm x 34mm x 0.55B.M.T. steel studs, friction fitted into C-Section track 64mm x 30mm x 0.55B.M.T.

Cavity must be 86mm overall between the framing. Framing not to touch KOROK® panel.

Framing must be installed as per manufacturer's instructions.

ACOUSTIC INSULATION

Acoustic insulation must be either Greenstuf Sound Solution® Plus 75 or Pink® Batts® R1.8 or equivalent each side.

Or omitting the insulation fixed to the KOROK® wall above ceiling height and laying a minimum R1.8 insulation over the ceiling.

LINING

1 layer of 13mm GIB® Standard plasterboard or equivalent on each side fixed vertically with all joints over framing to ceiling height.

Plasterboard linings are installed to the manufacturer's specification. Joints must be stopped.

SEALANT

Beads of fire-rated sealant are required around the perimeter of the KOROK® system.

Refer to the installation section of this publication for more information on sealant application.

Refer to the KOROK® Components Summary for approved sealants.

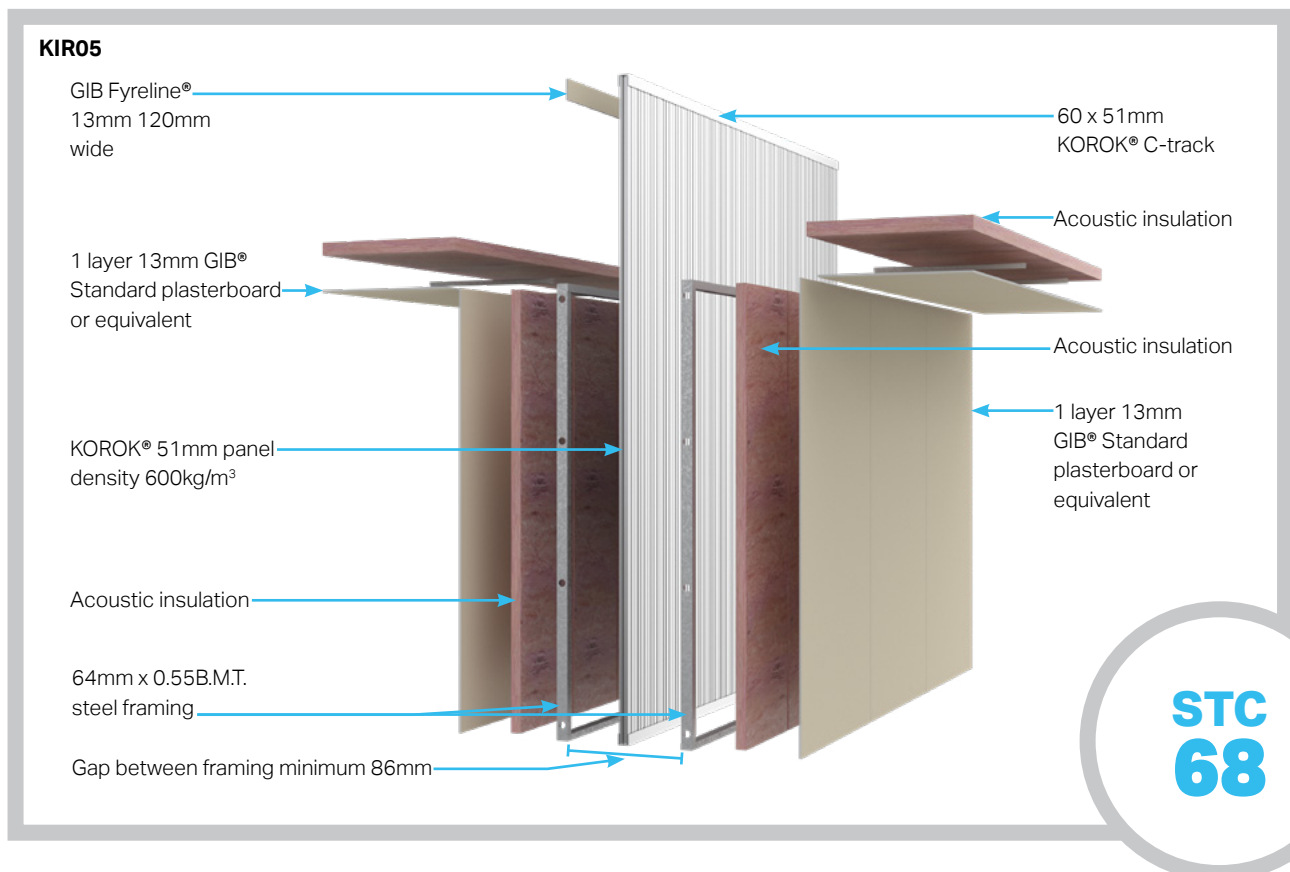

KIRO5 FRR -/60/60

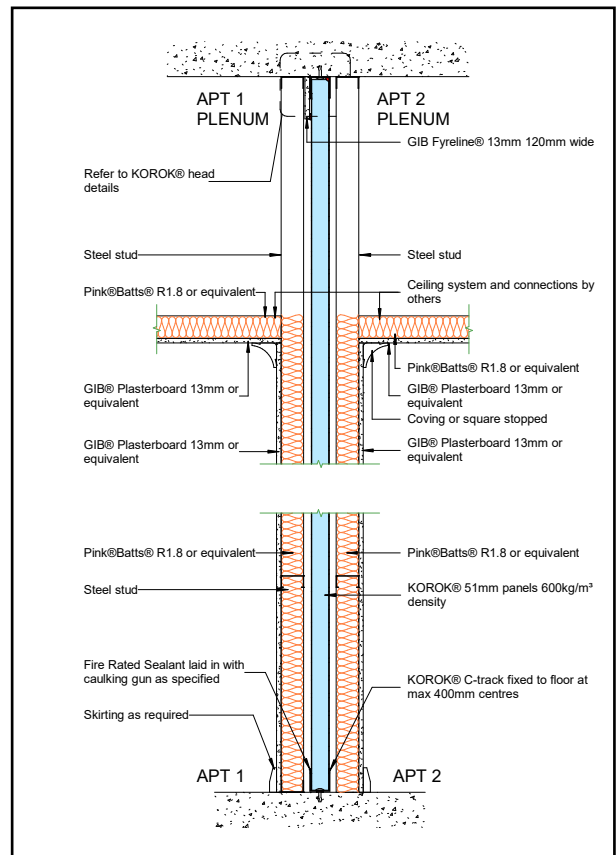
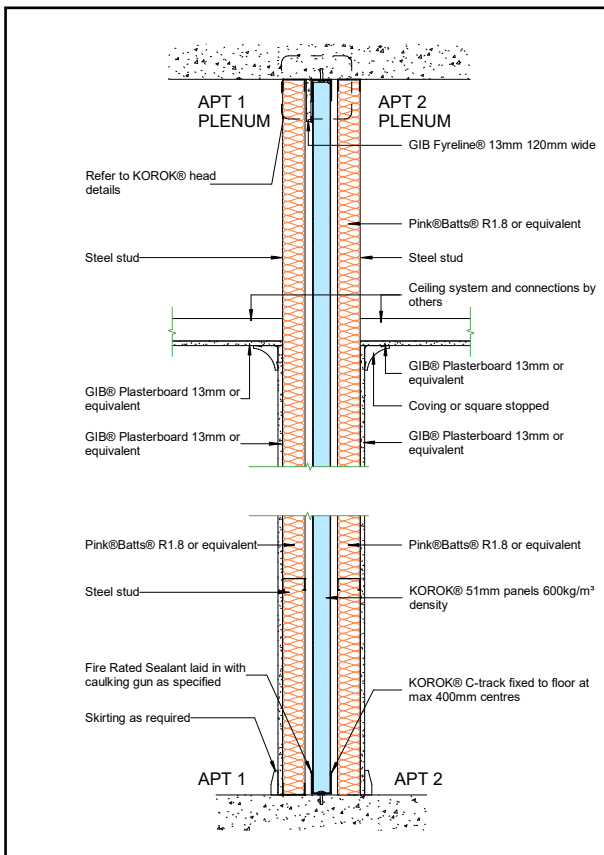
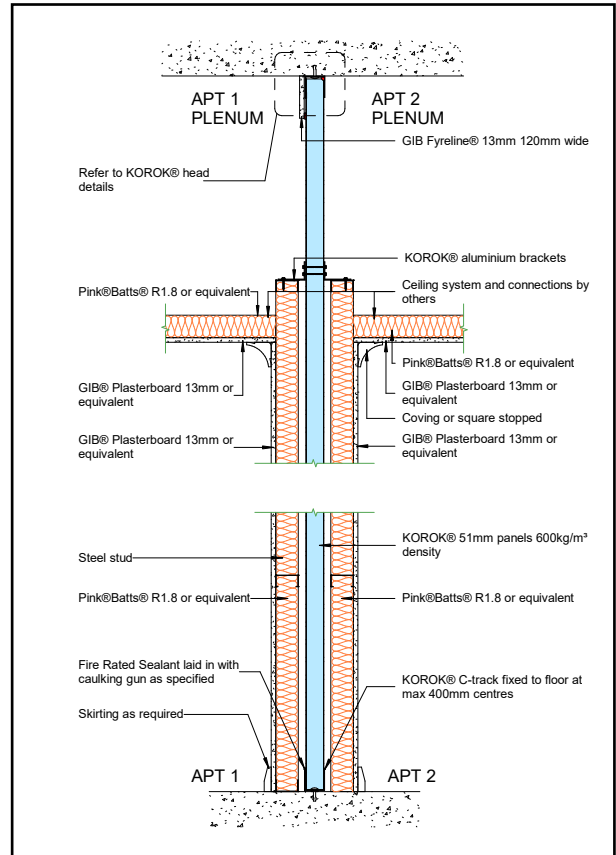
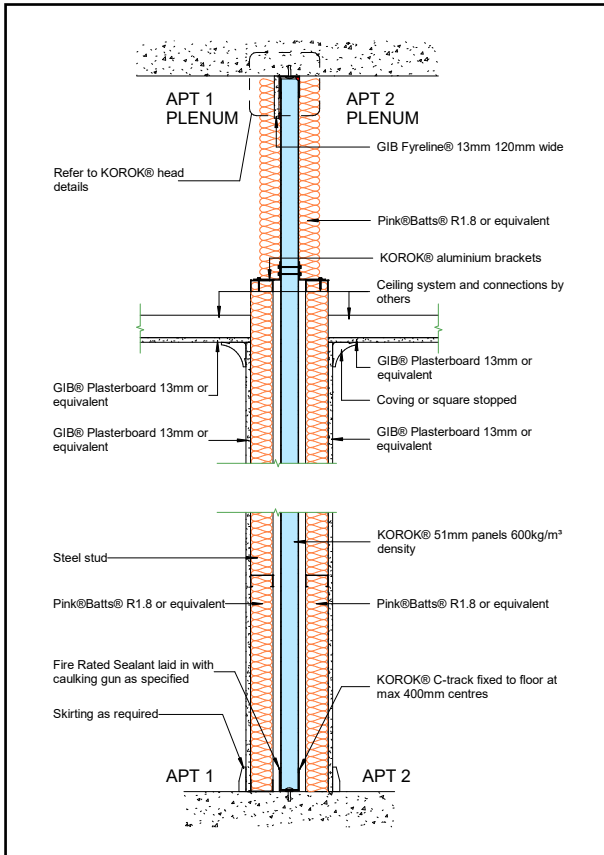

KIRO9 FRR -/60/60

SPEC. CODE	STC	FRR	WALL THICKNESS*	FRAME	CAVITY	SYSTEM SUMMARY
KIRO9	60	-/60/60	177mm	28mm Furring channel on BETAGRIP® Clips each side	N/A	KOROK® 51mm panels (600 kg/m ³ density) + 1 layer 13mm GIB Noiseline® or equivalent each side

*Nominal thickness

KOROK® PANEL

KOROK® 51mm panels are located in KOROK® C-track 60mm high x 51mm wide x 1.15B.M.T. The KOROK® C-track is fixed to the structure at 400mm centres max, and bedded on a bead of fire-rated sealant. KOROK® panels must not exceed 5 metres in height.

FRAMING

28mm Furring channel at 600mm maximum centres on each side, mounted on BETAGRIP® Clips directly fixed to KOROK® panel at maximum 1000mm centres.

Framing must be installed as per manufacturer's instructions.

ACOUSTIC INSULATION

Acoustic insulation must be Pink® Batts® R1.2 50mm 12.8 kg/m³ or equivalent each side.

Or omitting the insulation fixed to the KOROK® wall above ceiling height and laying a minimum R1.8 insulation over the ceiling.

LINING

1 layer of 13mm GIB Noiseline® or equivalent on each side to ceiling height.

Plasterboard linings are installed to the manufacturer's specification. Joints must be stopped.

SEALANT

Beads of fire-rated sealant are required around the perimeter of the KOROK® system.

Refer to the installation section of this publication for more information on sealant application.

Refer to the KOROK® Components Summary for approved sealants.

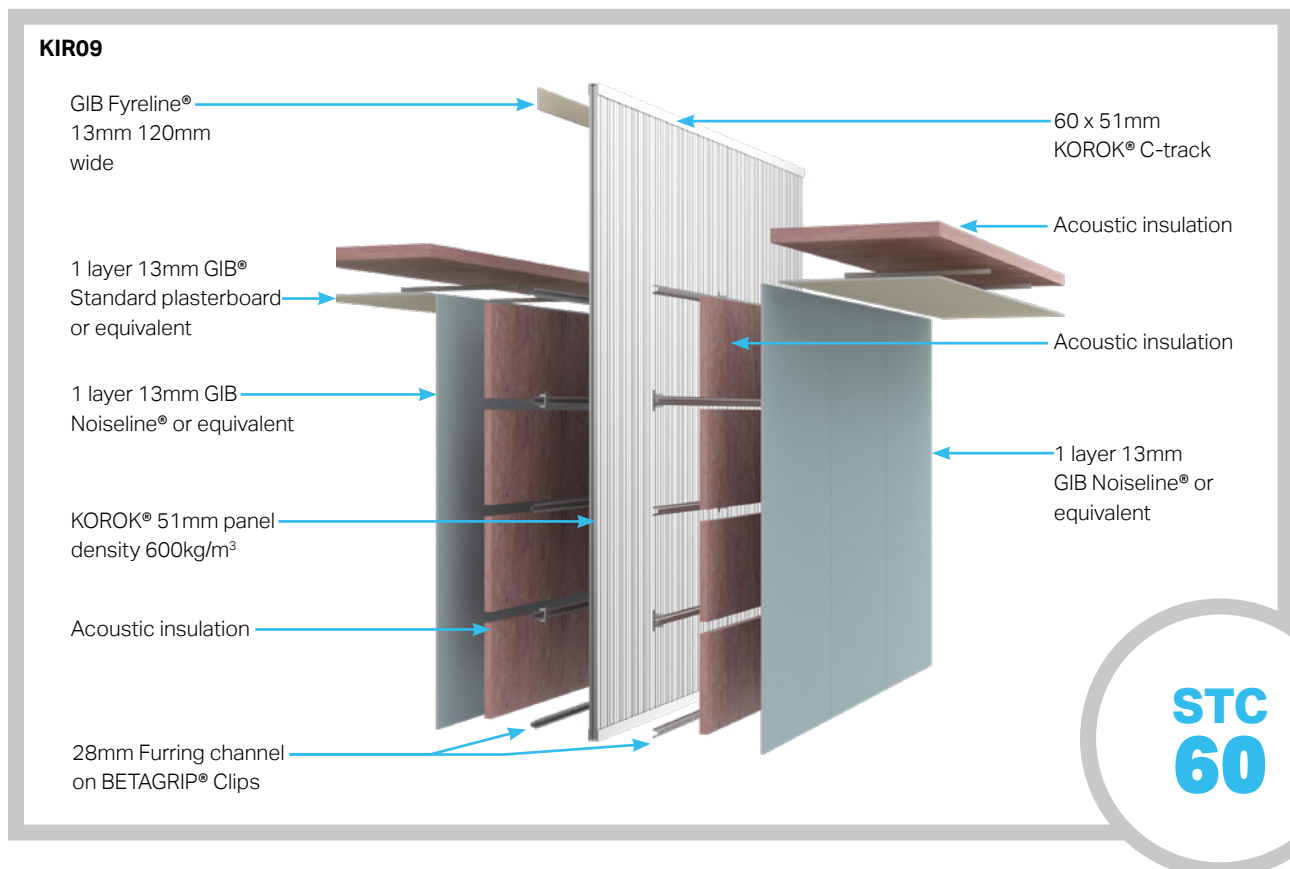

KIRO9 FRR -/60/60

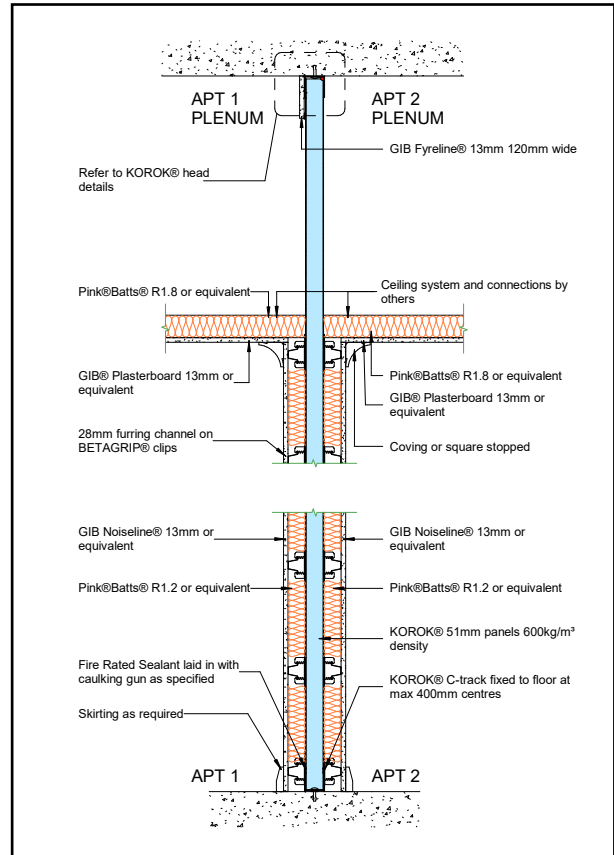
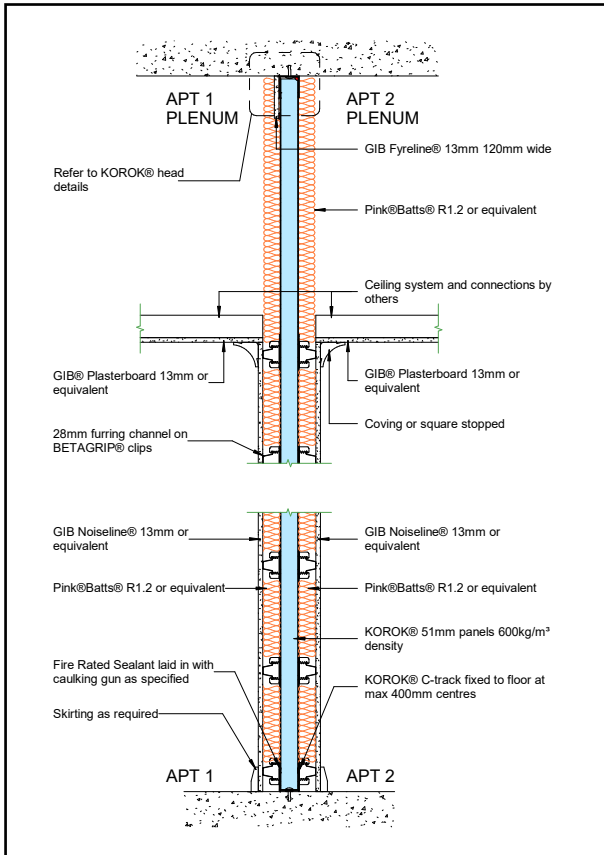

KIR14 FRR -/60/60

SPEC. CODE	STC	FRR	WALL THICKNESS*	FRAME	CAVITY	SYSTEM SUMMARY
KIR14	55	-/60/60	109mm	28mm Furring channel on resilient mounts one side	N/A	KOROK® 51mm panels (600 kg/m ³ density) + 1 layer of 13mm GIB Noiseline® or equivalent on one side

*Nominal thickness

KOROK® PANEL

KOROK® 51mm panels are located in KOROK® C-track 60mm high x 51mm wide x 1.15B.M.T. The KOROK® C-track is fixed to the structure at 400mm centres max, and bedded on a bead of fire-rated sealant. KOROK® panels must not exceed 5 metres in height.

FRAMING

28mm Furring channel at 600mm maximum centres one side mounted on ST001 Resilient Mounts fixed to KOROK® panel joints at 1000mm centres.

Framing must be installed as per manufacturer's instructions.

ACOUSTIC INSULATION

Acoustic insulation must be R1.3 GreenStuf® Masonry Wall Blanket or equivalent on the Furring channel side.

Or omitting the insulation fixed to the KOROK® wall above ceiling height and laying a minimum R1.8 insulation over the ceiling.

LINING

1 layer of 13mm GIB Noiseline® or equivalent on one side fixed vertically over Furring channel to ceiling height.

Plasterboard linings are installed to the manufacturer's specification. Joints must be stopped.

SEALANT

Beads of fire-rated sealant are required around the perimeter of the KOROK® system.

Refer to the installation section of this publication for more information on sealant application.

Refer to the KOROK® Components Summary for approved sealants.

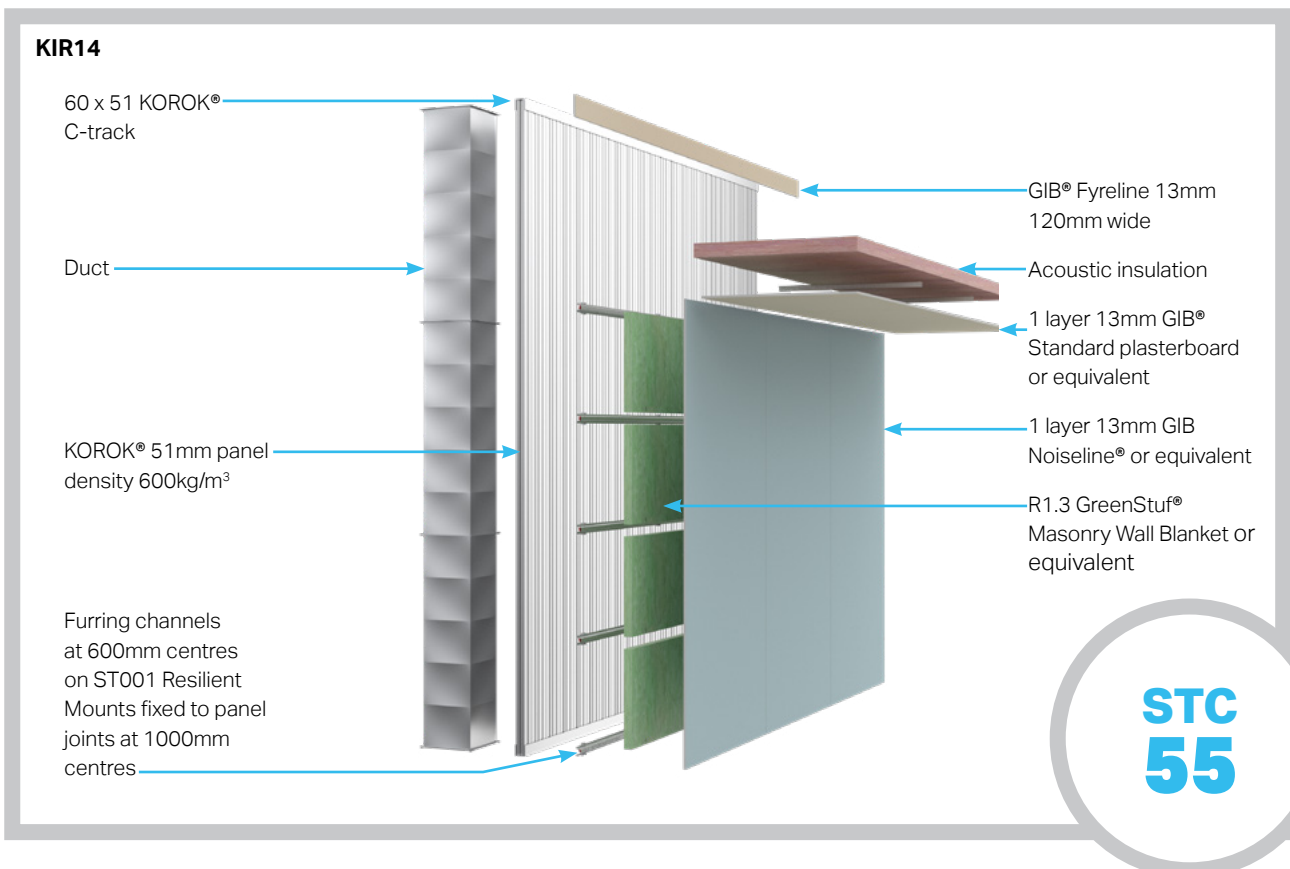

KIR14 FRR -/60/60

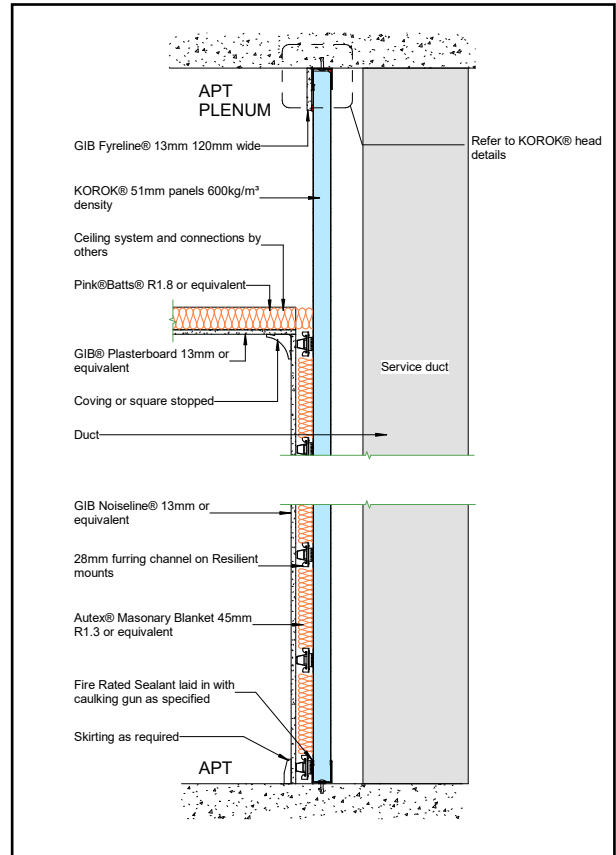
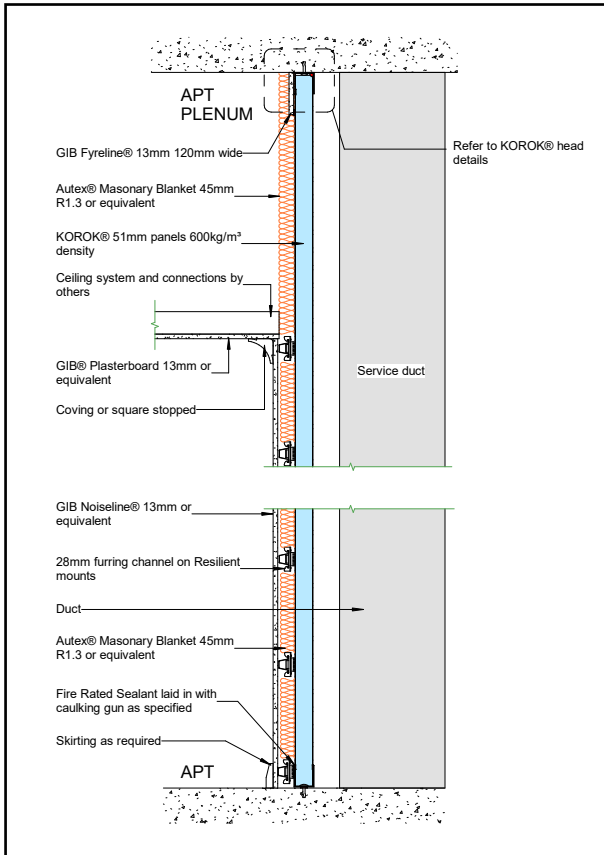

KIR15 FRR -/120/120

SPEC. CODE	STC	FRR	WALL THICKNESS*	FRAME	CAVITY	SYSTEM SUMMARY
KIR15	56	-/120/120	141mm	28mm Furring channel on BETAGRIP® Clips one side	N/A	KOROK® 78mm panels (400 kg/m ³ density) + 1 layer 13mm GIB Noiseline® or equivalent one side**

*Nominal thickness

KOROK® PANEL

KOROK® 78mm panels are located in KOROK® C-track 60mm high x 80mm wide x 1.15B.M.T. The KOROK® C-track is fixed to the structure at 400mm centres max, and bedded on a bead of fire-rated sealant. KOROK® panels must not exceed 6 metres in height.

FRAMING

28mm Furring channel at 600mm maximum centres mounted on BETAGRIP® Clips fixed to KOROK® panel joints at 1000mm centres each side.

ACOUSTIC INSULATION

Acoustic insulation must be Pink® Batts® R1.2 or equivalent on the Furring channel side.

Or omitting the insulation fixed to the KOROK® wall above ceiling height and laying a minimum R1.8 insulation over the ceiling.

LINING

1 layer of 13mm GIB® Standard plasterboard or equivalent on one side fixed vertically over Furring channel to ceiling height.

Plasterboard linings are installed to the manufacturer's specification. Joints must be stopped.

SEALANT

Beads of fire-rated sealant are required around the perimeter of the KOROK® system.

Refer to the installation section of this publication for more information on sealant application.

Refer to the KOROK® Components Summary for approved sealants.

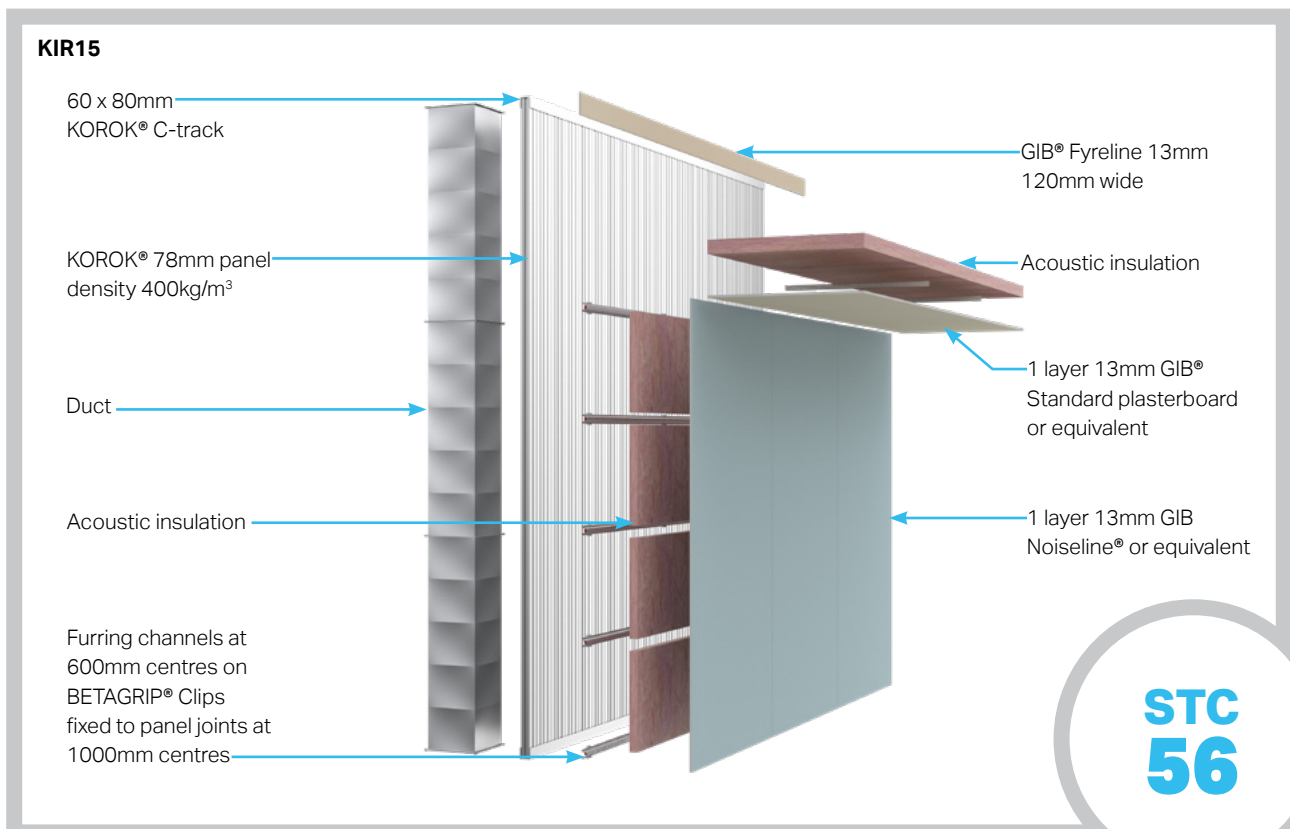

KIR15 FRR -/120/120

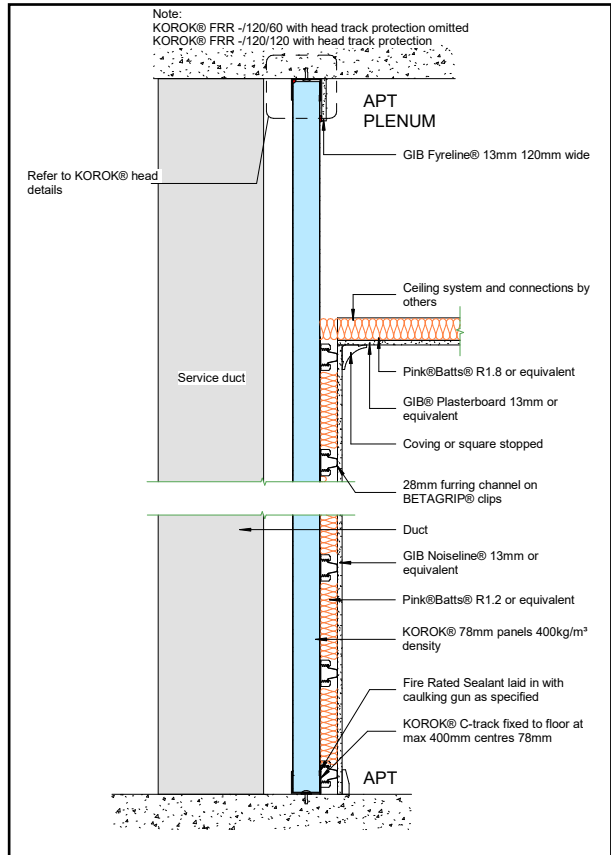
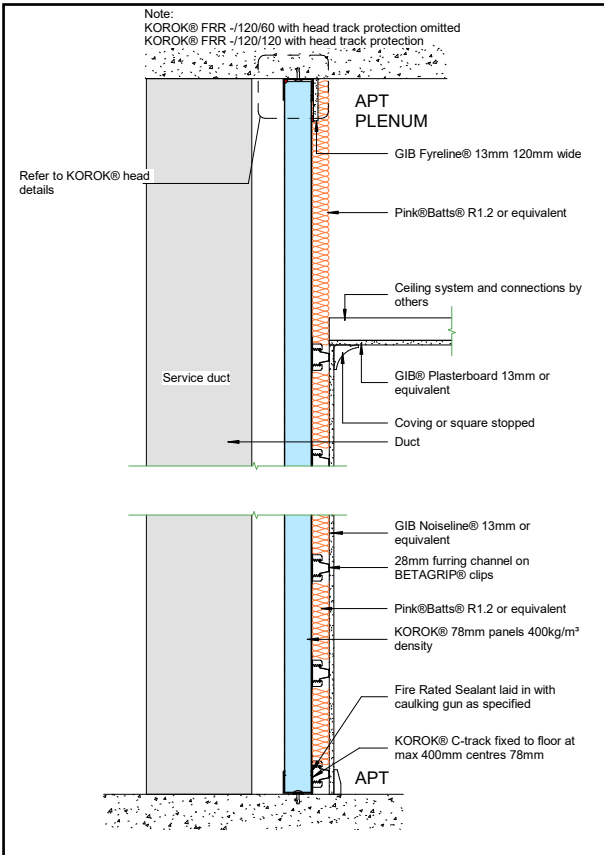

KIR17 FRR -/120/120

SPEC. CODE	STC	FRR	WALL THICKNESS*	FRAME	CAVITY	SYSTEM SUMMARY
KIR17	61	-/120/120	204mm	28mm Furring channel on BETAGRIP® Clips each side	N/A	KOROK® 78mm panels (400 kg/m ³ density) + 1 layer 13mm GIB Noiseline® or equivalent each side**

*Nominal thickness

KOROK® PANEL

KOROK® 78mm panels are located in KOROK® C-track 60mm high x 80mm wide x 1.15B.M.T. The KOROK® C-track is fixed to the structure at 400mm centres max, and bedded on a bead of fire-rated sealant. KOROK® panels must not exceed 6 metres in height.

FRAMING

28mm Furring channel at 600mm maximum centres mounted on BETAGRIP® Clips fixed to KOROK® panel joints at 1000mm centres each side.

ACOUSTIC INSULATION

Acoustic insulation must be Pink® Batts® R1.2 or equivalent each side.

Or omitting the insulation fixed to the KOROK® wall above ceiling height and laying a minimum R1.8 insulation over the ceiling.

LINING

1 layer of 13mm GIB Noiseline® or equivalent on each side fixed vertically to ceiling height.

Plasterboard linings are installed to the manufacturer's specification. Joints must be stopped.

SEALANT

Beads of fire-rated sealant are required around the perimeter of the KOROK® system.

Refer to the installation section of this publication for more information on sealant application.

Refer to the KOROK® Components Summary for approved sealants.

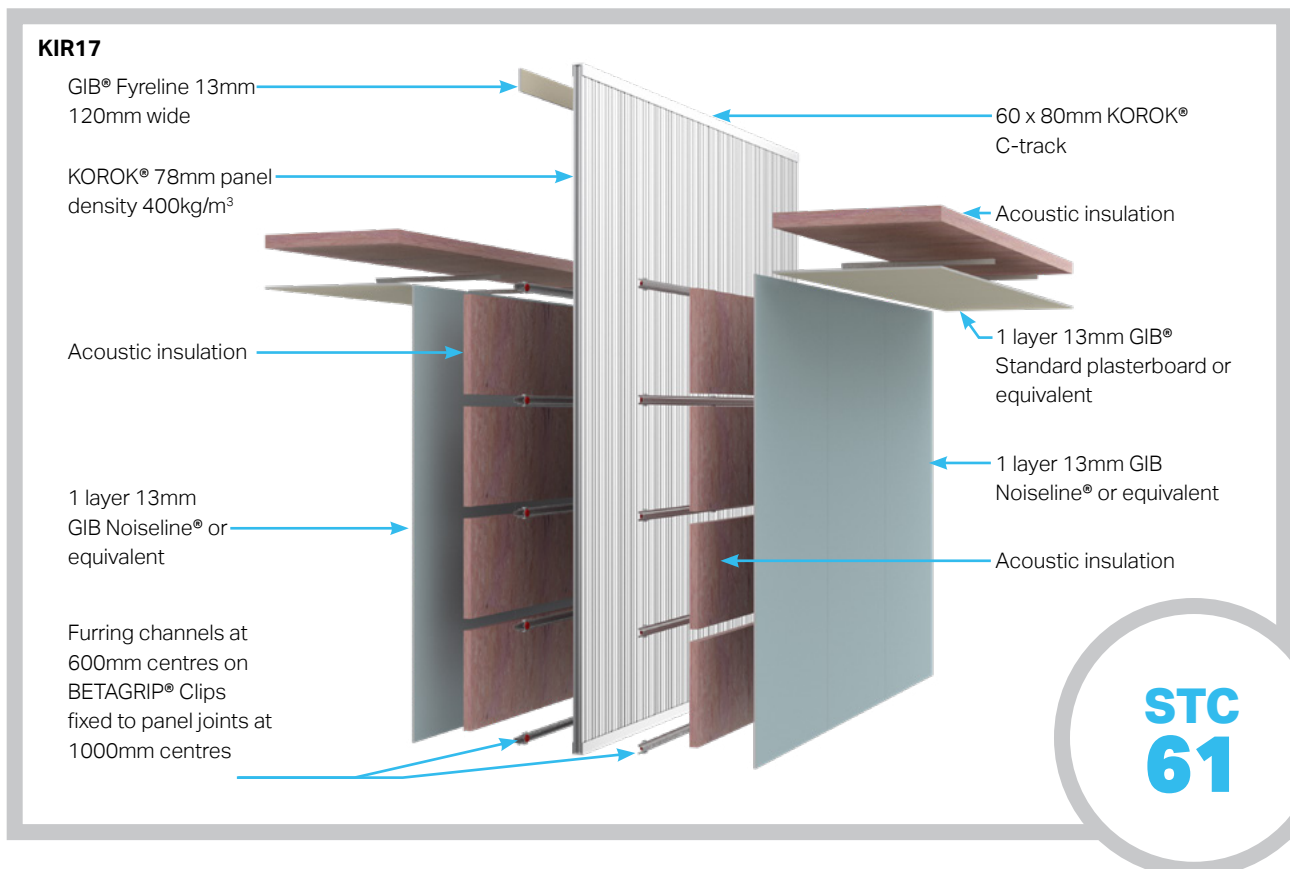

KIR17 FRR -/120/120

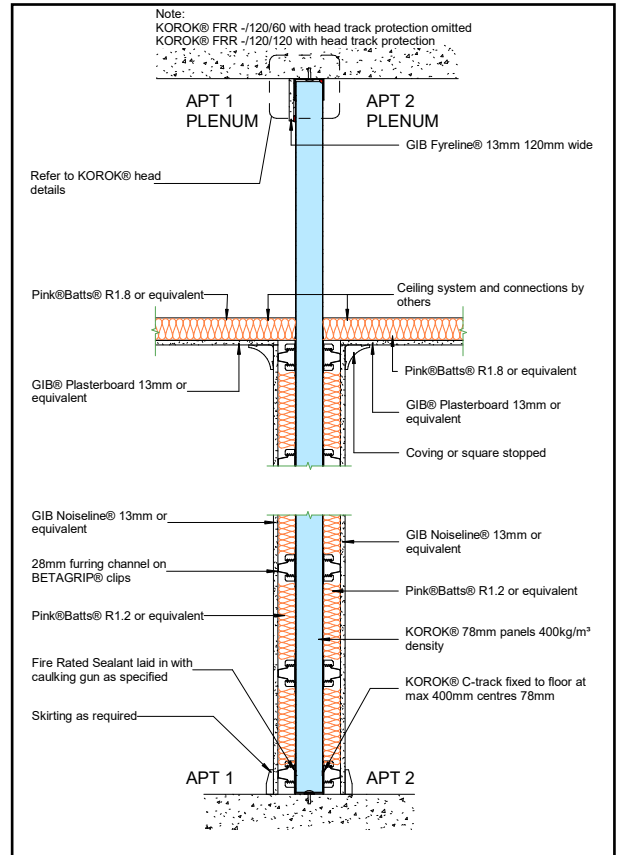
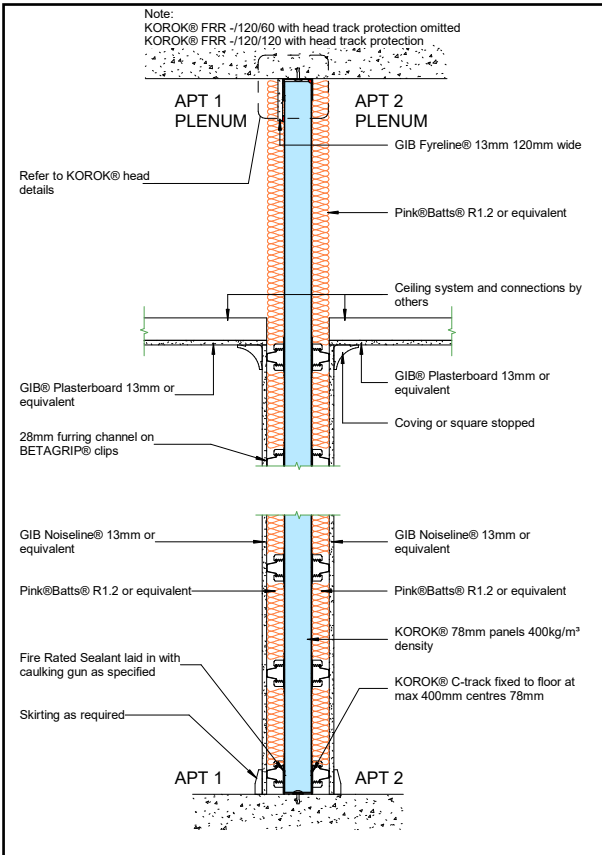

KIR20 FRR -/120/120

SPEC. CODE	STC	FRR	WALL THICKNESS*	FRAME	CAVITY	SYSTEM SUMMARY
KIR20	60	-/120/120	233mm	64mm Steel frame one side, 28mm Furring channel on BETAGRIP® Clips the other side	Minimum 15mm	KOROK® 78mm panels (400 kg/m ³ density) + 1 layer 13mm GIB Noiseline® or equivalent one side + 1 layer 13mm GIB® Standard plasterboard or equivalent the other side**

*Nominal thickness

KOROK® PANEL

KOROK® 78mm panels are located in KOROK® C-track 60mm high x 80mm wide x 1.15B.M.T. The KOROK® C-track is fixed to the structure at 400mm centres max, and bedded on a bead of fire-rated sealant. KOROK® panels must not exceed 6 metres in height.

FRAMING

28mm Furring channel at 600mm maximum centres mounted on BETAGRIP® Clips fixed to KOROK® panel joints at 1000mm centres each side.

Framing must be installed as per manufacturer's instructions.

ACOUSTIC INSULATION

Acoustic insulation must be Pink® Batts® R1.2 or equivalent each side.

Or omitting the insulation fixed to the KOROK® wall above

ceiling height and laying a minimum R1.8 insulation over the ceiling.

LINING

1 layer of 13mm GIB Noiseline® or equivalent one side and one layer of 13mm GIB® Standard plasterboard or equivalent the other, to ceiling height.

Plasterboard linings are installed to the manufacturer's specification. Joints must be stopped.

SEALANT

Beads of fire-rated sealant are required around the perimeter of the KOROK® system.

Refer to the installation section of this publication for more information on sealant application.

Refer to the KOROK® Components Summary for approved sealants.

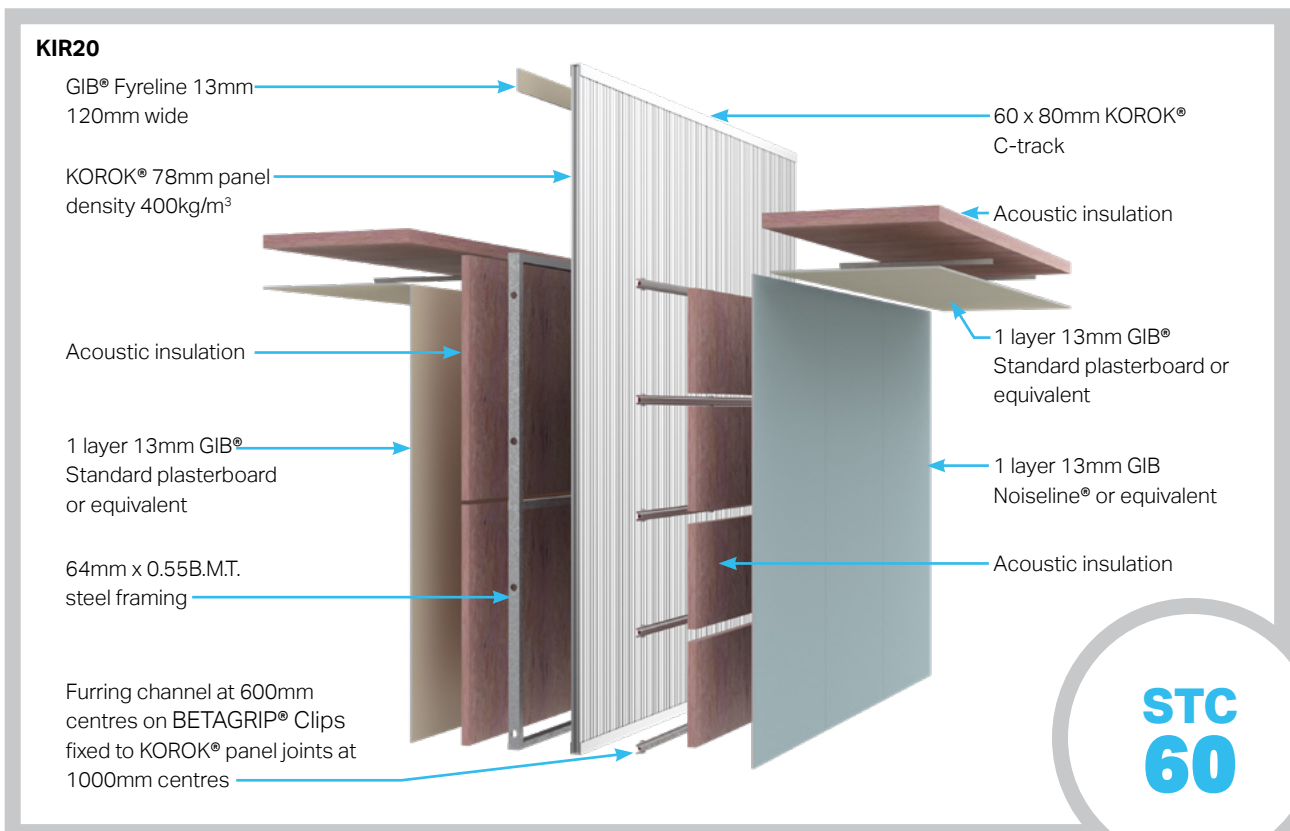

KIR20 FRR -/120/120

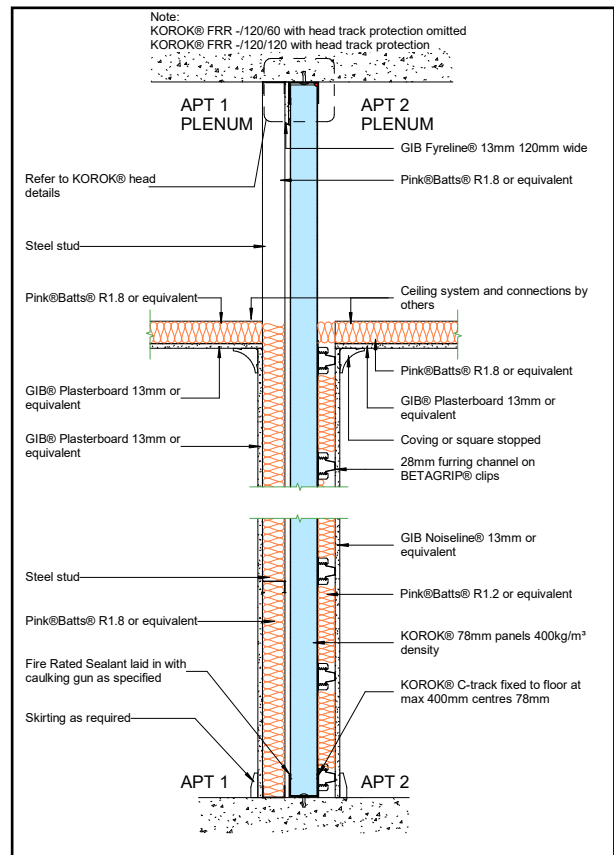
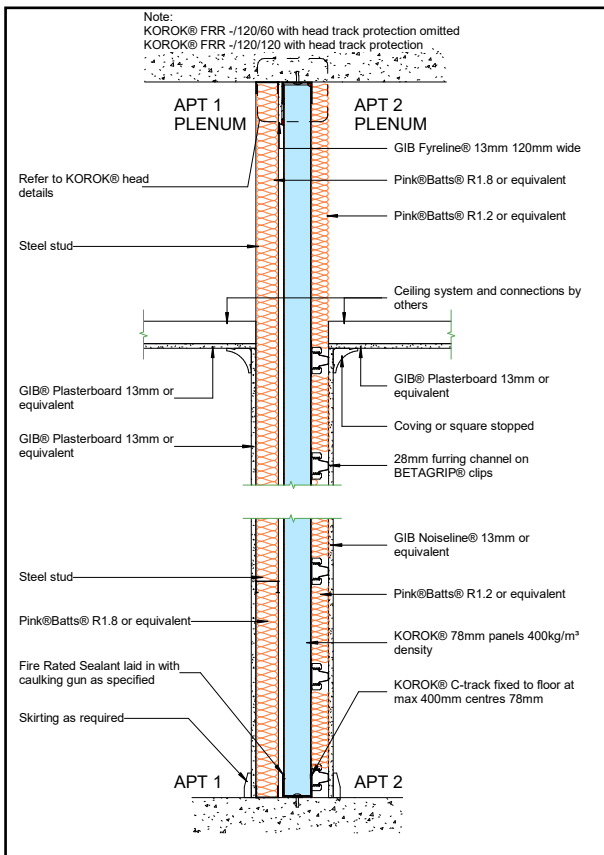
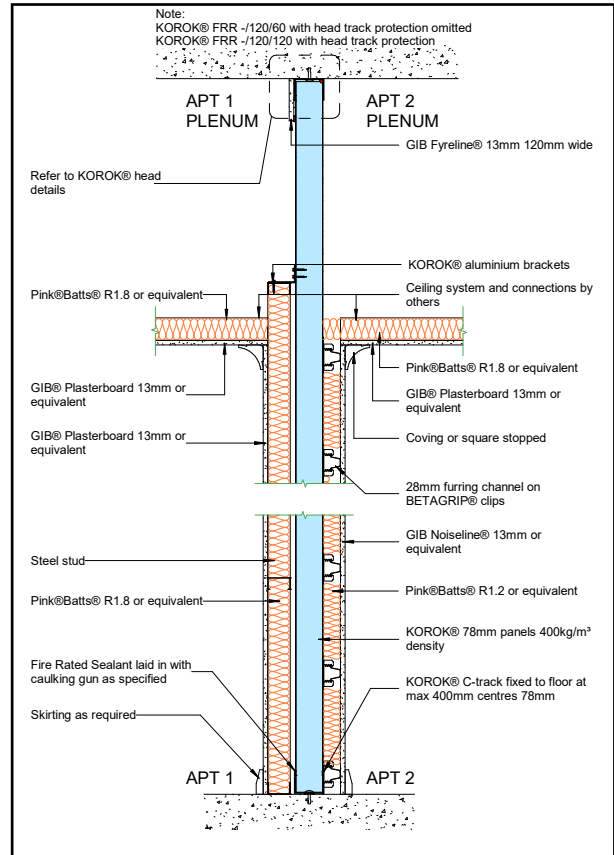
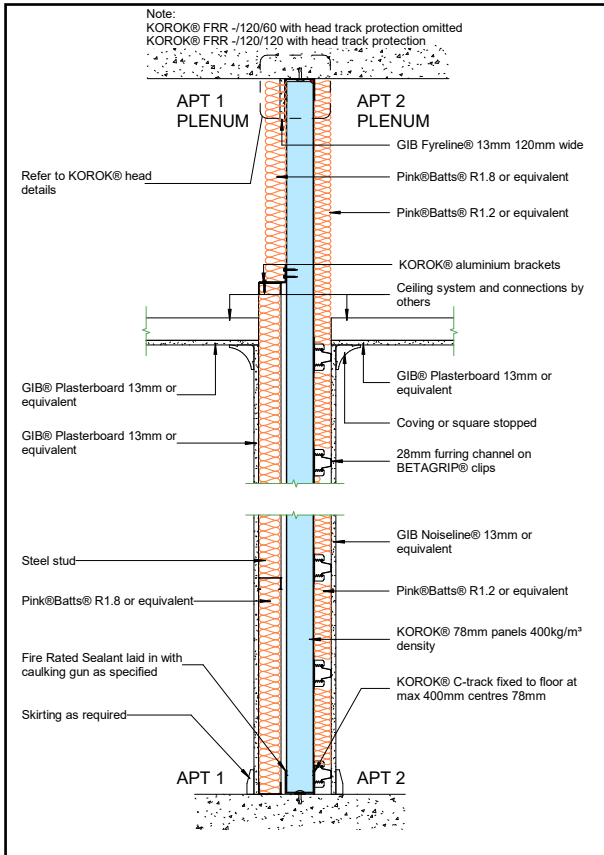

KIR21 FRR -/120/120

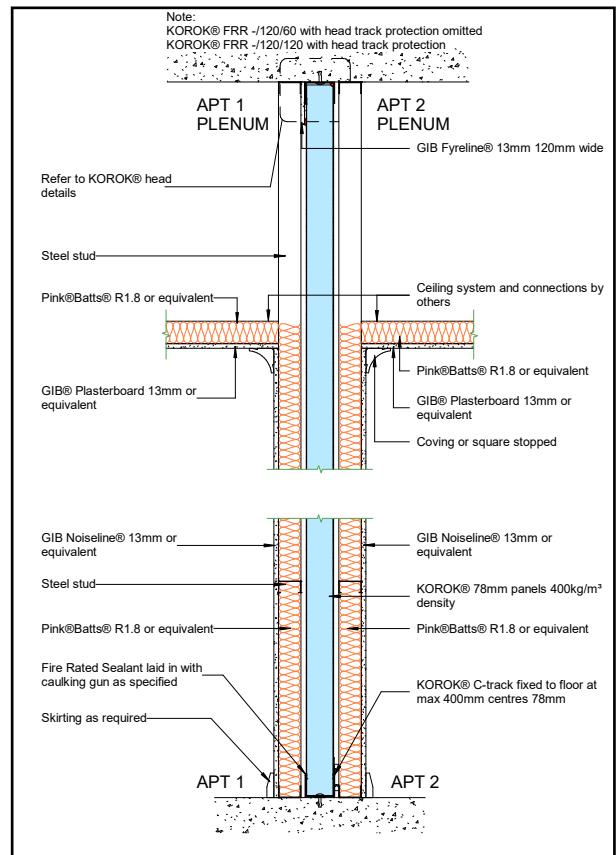
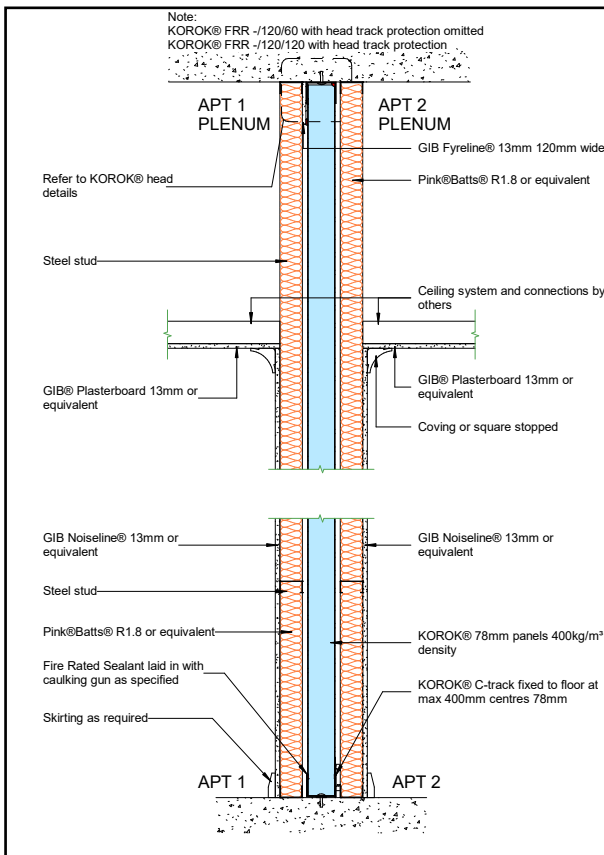
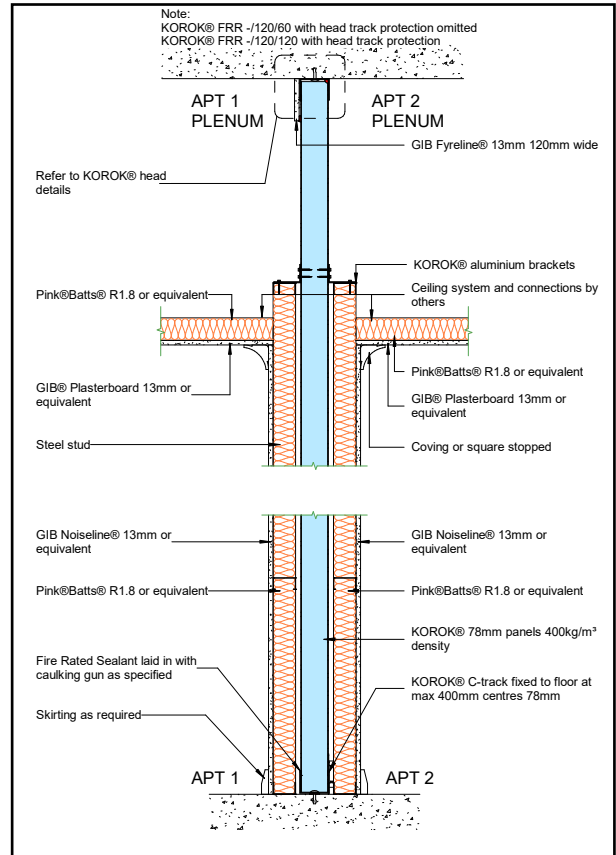
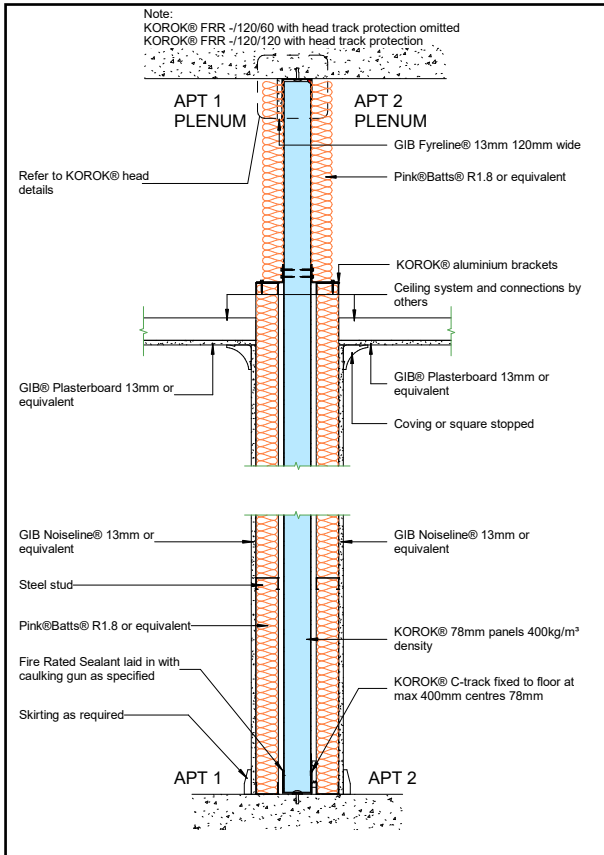

KOROK® INTERTENANCY APARTMENT SYSTEMS

TABLE 2 - KIM (KOROK® INTERTENANCY MULTILEVEL) SYSTEMS SUMMARY TABLE

SPEC. CODE	STC	FRR	WALL THICKNESS*	FRAME	CAVITY	SYSTEM SUMMARY	PAGE
KIM01	58	-/60/60	194mm	64mm Steel frame one side 28mm Furring channel on direct fix clips the other	Minimum 20mm	KOROK® 51mm panels (600 kg/m ³ density) + 1 layer 13mm GIB® Standard plasterboard or equivalent each side**	32
KIM02	57	-/60/60	122mm	28mm Furring channel on resilient mounts one side	N/A	KOROK® 51mm panels (600 kg/m ³ density) + 1 layer 13mm GIB Noiseline® or equivalent each side**	33
KIM03	59	-/60/60	167mm	28mm Furring channel on resilient mounts each side	N/A	KOROK® 51mm panels (600 kg/m ³ density) + 1 layer 13mm GIB Noiseline® or equivalent each side**	34
KIM04	59	-/60/60	161mm	64mm Steel frame one side	Minimum 20mm	KOROK® 51mm panels (600 kg/m ³ density) + 1 layer 13mm GIB® Standard plasterboard or equivalent each side**	35
KIM05	68	-/60/60	240mm	64mm Steel frame each side	Minimum 86mm between the framing. Framing not to touch KOROK® panel	KOROK® 51mm panels (600 kg/m ³ density) + 1 layer 13mm GIB® Standard plasterboard or equivalent each side**	36
KIM06	59	-/120/120	188mm	64mm steel frame one side	Minimum 20mm	KOROK® 78mm panels (400 kg/m ³ density) + 1 layer 13mm GIB Noiseline® or equivalent one side + 1 layer 13mm GIB® Standard plasterboard or equivalent other side**	37
KIM07	59	-/120/120	188mm	64mm steel frame one side	Minimum 20mm	KOROK® 78mm panels (400 kg/m ³ density) + 1 layer 13mm GIB® Standard plasterboard or equivalent each side**	38
KIM08	61	-/60/60	182mm	64mm steel frame one side 16mm Furring channel on direct fix clips the other	Minimum 20mm	KOROK® 51mm panels (600 kg/m ³ density) + 1 layer 13mm GIB Noiseline® or equivalent each side**	39
KIM09	60	-/60/60	175mm	28mm Furring channel on BETAGRIP® Clips each side	N/A	KOROK® 51mm panels (600 kg/m ³ density) + 1 layer 13mm GIB Noiseline® or equivalent each side**	40
KIM12	61	-/60/60	167mm	64mm steel frame one side 16mm Furring channel directly fixed the other	Minimum 10mm	KOROK® 51mm panels (600 kg/m ³ density) + 1 layer 13mm GIB Noiseline® or equivalent each side**	41
KIM13	64	-/60/60	194mm	64mm steel frame one side 16mm Furring channel on direct fix clips the other	Minimum 20mm	KOROK® 51mm panels (600 kg/m ³ density) + 1 layer 13mm GIB Noiseline® or equivalent one side +2 layers 13mm GIB Noiseline® or equivalent the other**	38

*Nominal thickness

**Acoustic insulation for each system is as per specification sheet

DEFLECTION C-TRACK DETAILS Dead and live loads can cause significant deflection in some structures.

KOROK® can provide deflection C-track details where deflection loadings are considered.

KIM01 FRR -/60/60

SPEC. CODE	STC	FRR	WALL THICKNESS*	FRAME	CAVITY	SYSTEM SUMMARY
KIM01	58	-/60/60	194mm	64mm Steel frame one side. 28mm Furring channel on direct fix clips the other	Minimum 20mm	KOROK® 51mm panels (600 kg/m ³ density) + 1 layer 13mm GIB® Standard plasterboard or equivalent each side

KOROK® PANEL

KOROK® 51mm panels are located in KOROK® C-track 60mm high x 51mm wide x 1.15B.M.T. The KOROK® C-track is fixed to the structure at 400mm centres max, and bedded on a bead of fire-rated sealant. KOROK® panels must not exceed 5 metres in height.

FRAMING

64mm x 34mm x 0.55B.M.T. steel studs, friction fitted into C-Section track one side.

Allow a minimum 20mm gap between the framing and the KOROK® panel.

28mm Furring channel at 600mm maximum centres mounted on direct fix clips on the other.

Framing must be installed as per manufacturer's instructions.

ACOUSTIC INSULATION

Acoustic insulation must be either Greenstuf Sound

*Nominal thickness Solution® Plus 75 or Pink® Batts® R1.8 or equivalent within the steel stud side and R0.5 GreenStuf® Masonry Wall Blanket or equivalent on the Furring channel side.

LINING

Frames are lined with 1 layer of 13mm GIB® Standard plasterboard or equivalent on each side fixed vertically with joints over framing one side and on Furring channels at 600mm maximum centres on the other.

Plasterboard linings are installed to the manufacturer's specification. Joints must be stopped.

SEALANT

Beads of fire-rated sealant are required around the perimeter of the KOROK® system.

Refer to the installation section of this publication for more information on sealant application.

Refer to the KOROK® Components Summary for approved sealants.

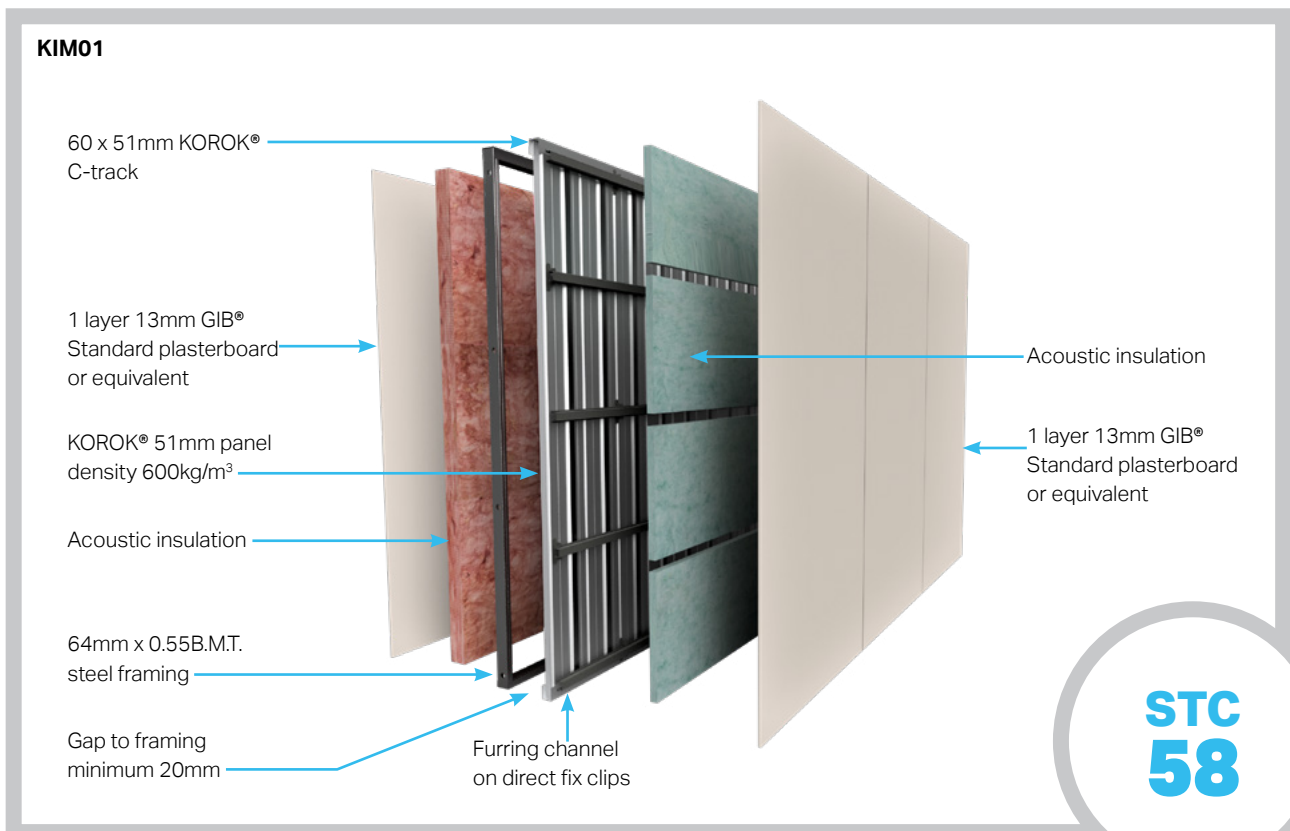

KIM02 FRR -/60/60

SPEC. CODE	STC	FRR	WALL THICKNESS*	FRAME	CAVITY	SYSTEM SUMMARY
KIM02	57	-/60/60	122mm	28mm Furring channel on resilient mounts one side	N/A	KOROK® 51mm panels (600 kg/m³ density) + 1 layer of 13mm GIB Noiseline® or equivalent on each side

*Nominal thickness

KOROK® PANEL

KOROK® 51mm panels are located in KOROK® C-track 60mm high x 51mm wide x 1.15B.M.T. The KOROK® C-track is fixed to the structure at 400mm centres max, and bedded on a bead of fire-rated sealant. KOROK® panels must not exceed 5 metres in height.

FRAMING

28mm Furring channel at 600mm maximum centres one side mounted on ST001 Resilient Mounts fixed to KOROK® panel joints at 1000mm centres.

Framing must be installed as per manufacturer's instructions.

ACOUSTIC INSULATION

Acoustic insulation must be R1.3 GreenStuf® Masonry Wall Blanket or equivalent on the Furring channel side.

LINING

1 layer of 13mm GIB Noiseline® or equivalent on one side fixed vertically over Furring channel and 1 layer of 13mm GIB Noiseline® or equivalent the other.

Plasterboard linings are installed to the manufacturer's specification. Joints must be stopped.

SEALANT

Beads of fire-rated sealant are required around the perimeter of the KOROK® system.

Refer to the installation section of this publication for more information on sealant application.

Refer to the KOROK® Components Summary for approved sealants.

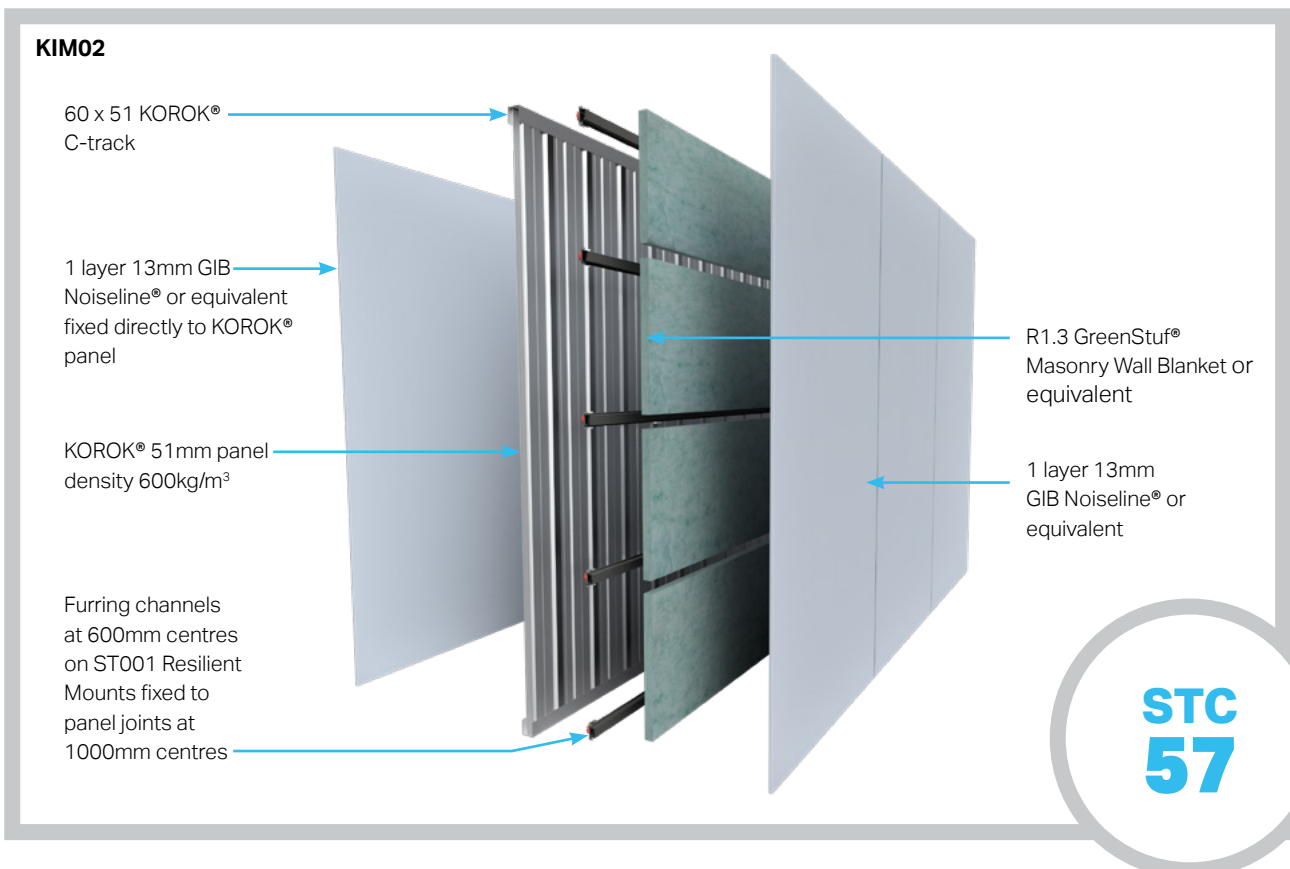

KIM03 FRR -/60/60

SPEC. CODE	STC	FRR	WALL THICKNESS*	FRAME	CAVITY	SYSTEM SUMMARY
KIM03	59	-/60/60	167mm	28mm Furring channel on resilient mounts each side	N/A	KOROK® 51mm panels (600 kg/m ³ density) + 1 layer 13mm GIB Noiseline® or equivalent each side

*Nominal thickness

KOROK® PANEL

KOROK® 51mm panels are located in KOROK® C-track 60mm high x 51mm wide x 1.15B.M.T. The KOROK® C-track is fixed to the structure at 400mm centres max, and bedded on a bead of fire-rated sealant. KOROK® panels must not exceed 5 metres in height.

FRAMING

28mm Furring channel at 600mm maximum centres mounted on ST001 Resilient Mounts fixed to KOROK® panel joints at 1000mm centres each side.

Framing must be installed as per manufacturer's instructions.

ACOUSTIC INSULATION

Acoustic insulation must be R1.3 GreenStuf® Masonry Wall Blanket or equivalent each side.

LINING

1 layer of 13mm GIB Noiseline® or equivalent on each side fixed vertically.

Plasterboard linings are installed to the manufacturer's specification. Joints must be stopped.

SEALANT

Beads of fire-rated sealant are required around the perimeter of the KOROK® system.

Refer to the installation section of this publication for more information on sealant application.

Refer to the KOROK® Components Summary for approved sealants.

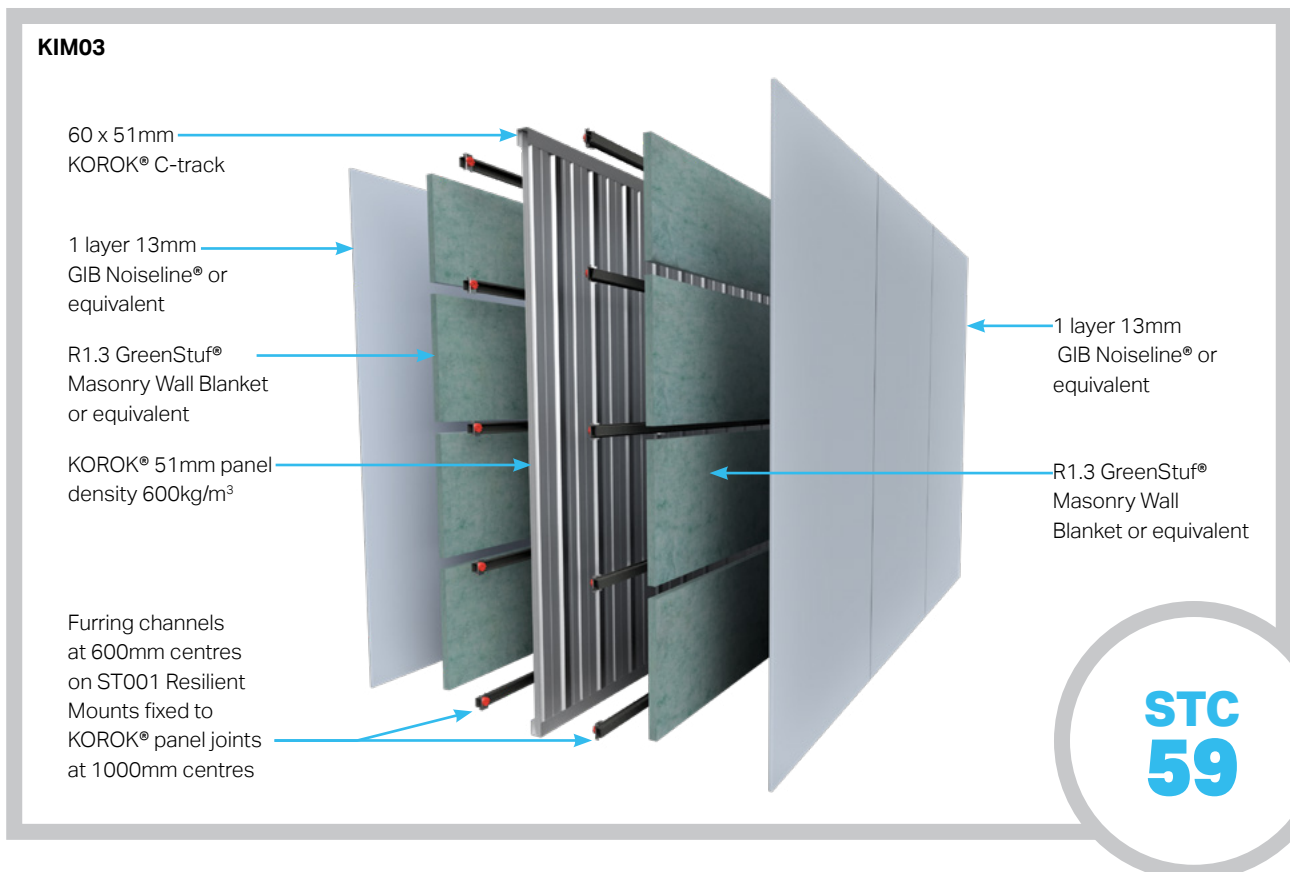

KIM04 FRR -/60/60

SPEC. CODE	STC	FRR	WALL THICKNESS*	FRAME	CAVITY	SYSTEM SUMMARY
KIM04	59	-/60/60	161mm	64mm Steel frame one side	Minimum 20mm	KOROK® 51mm panels (600 kg/m ³ density) + 1 layer 13mm GIB® Standard plasterboard or equivalent each side

*Nominal thickness

KOROK® PANEL

KOROK® 51mm panels are located in KOROK® C-track 60mm high x 51mm wide x 1.15B.M.T. The KOROK® C-track is fixed to the structure at 400mm centres max, and bedded on a bead of fire-rated sealant. KOROK® panels must not exceed 5 metres in height.

FRAMING

64mm x 34mm x 0.55B.M.T. steel studs, friction fitted into C-Section track 64mm x 30mm x 0.55B.M.T.

Allow a minimum 20mm gap between the framing and the KOROK® panel.

Framing must be installed as per manufacturer's instructions.

ACOUSTIC INSULATION

Acoustic insulation must be either Greenstuf Sound Solution® Plus 75 or Pink® Batts® R1.8 or equivalent within the steel stud side.

LINING

1 layer of 13mm GIB® Standard plasterboard or equivalent on each side fixed vertically with joints over framing one side and direct-fixed the other.

Plasterboard linings are installed to the manufacturer's specification. Joints must be stopped.

SEALANT

Beads of fire-rated sealant are required around the perimeter of the KOROK® system.

Refer to the installation section of this publication for more information on sealant application.

Refer to the KOROK® Components Summary for approved sealants.

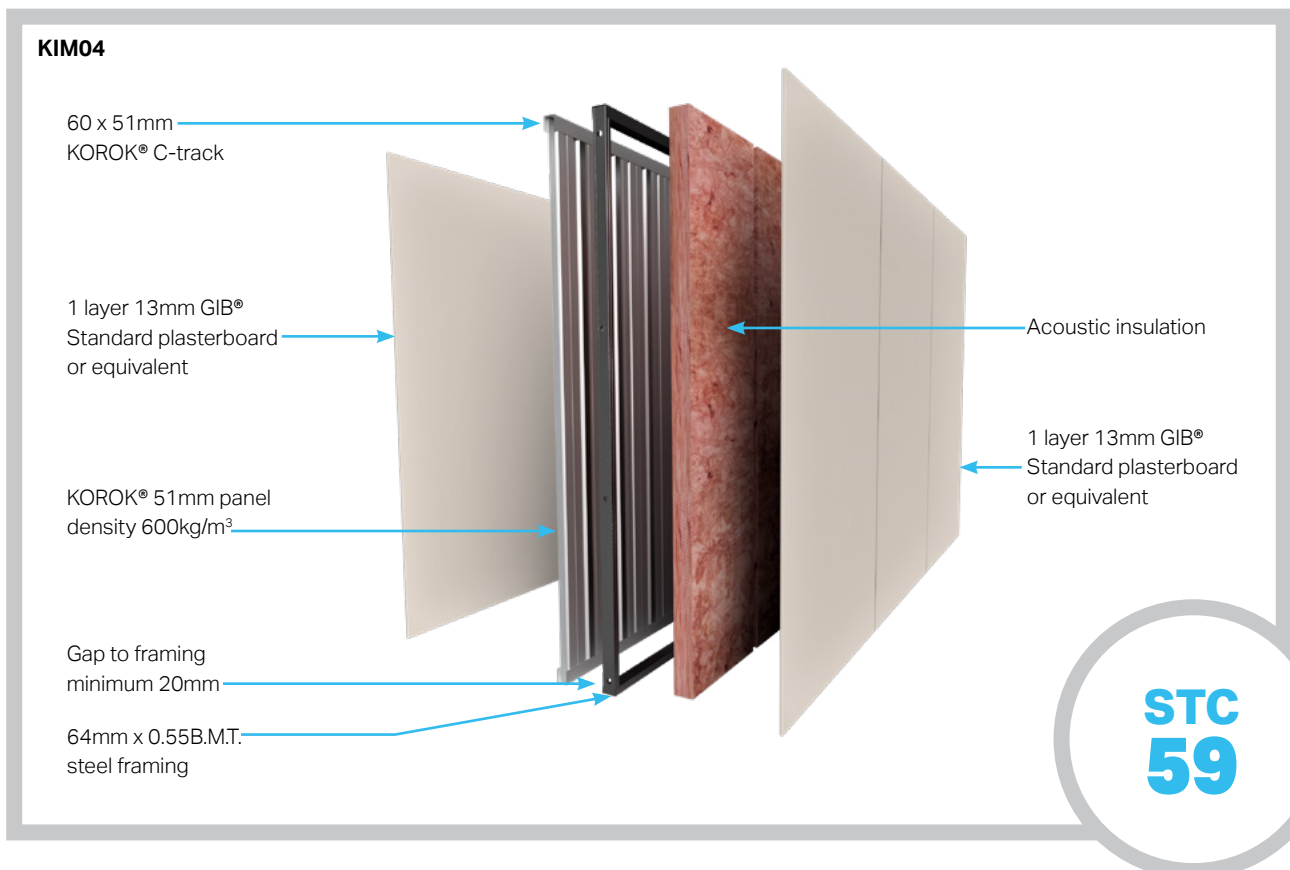

KIM05 FRR -/60/60

SPEC. CODE	STC	FRR	WALL THICKNESS*	FRAME	CAVITY	SYSTEM SUMMARY
KIM05	68	-/60/60	240mm	64mm Steel frame each side	Minimum 86mm overall between the framing. Framing not to touch KOROK® panel	KOROK® 51mm panels (600 kg/m ³ density) + 1 layer 13mm GIB® Standard plasterboard or equivalent each side

*Nominal thickness

KOROK® PANEL

KOROK® 51mm panels are located in KOROK® C-track 60mm high x 51mm wide x 1.15B.M.T. The KOROK® C-track is fixed to the structure at 400mm centres max, and bedded on a bead of fire-rated sealant. KOROK® panels must not exceed 5 metres in height.

FRAMING

64mm x 34mm x 0.55B.M.T. steel studs, friction fitted into C-Section track 64mm x 30mm x 0.55B.M.T.

Cavity must be 86mm overall between the framing. Framing not to touch KOROK® panel.

Framing must be installed as per manufacturer's instructions.

LINING

1 layer of 13mm GIB® Standard plasterboard or equivalent on each side fixed vertically with all joints over framing.

Plasterboard linings are installed to the manufacturer's specification. Joints must be stopped.

SEALANT

Beads of fire-rated sealant are required around the perimeter of the KOROK® system.

Refer to the installation section of this publication for more information on sealant application.

Refer to the KOROK® Components Summary for approved sealants.

ACOUSTIC INSULATION

Acoustic insulation must be either Greenstuf Sound Solution® Plus 75 or Pink® Batts® R1.8 or equivalent each side.

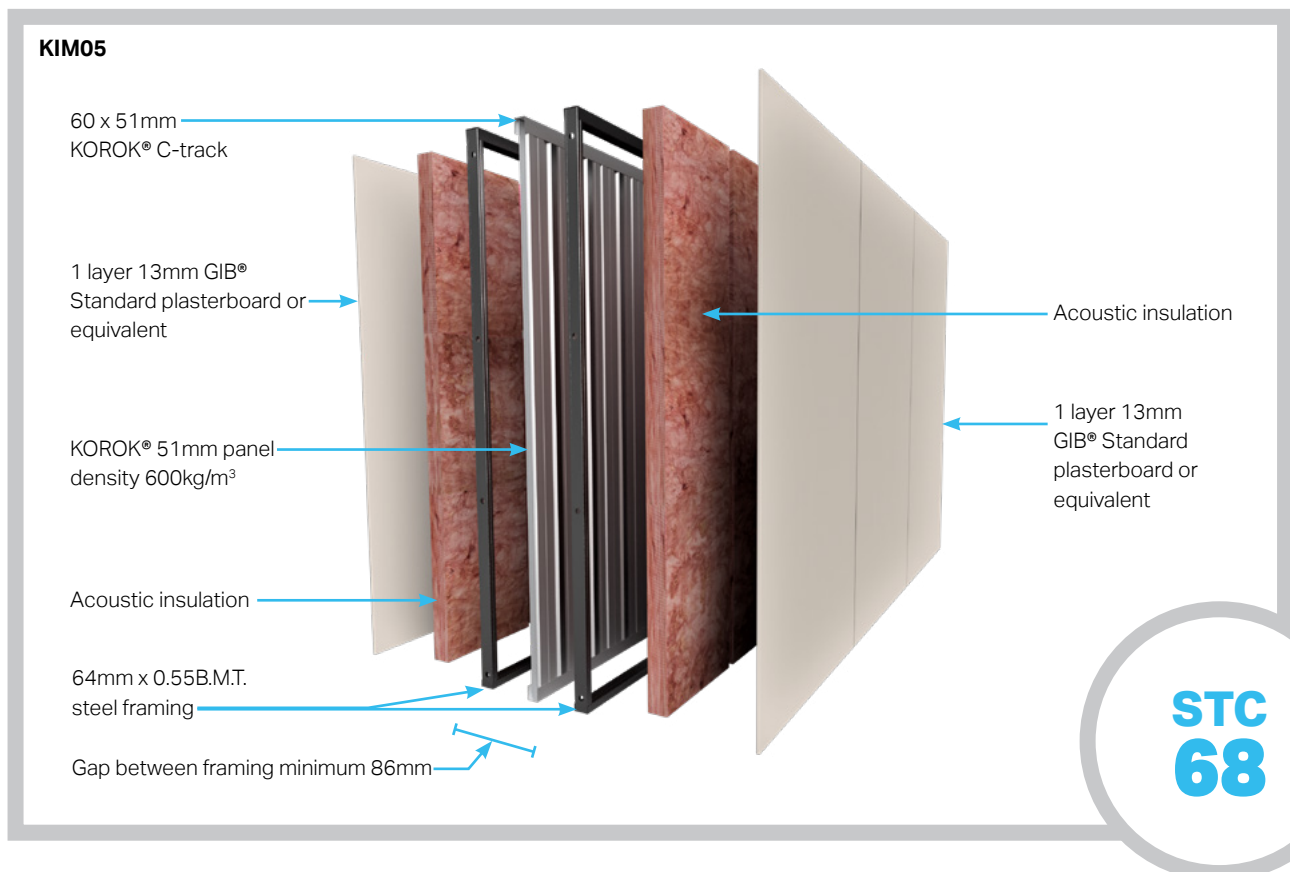

KIM06 FRR -/120/120

SPEC. CODE	STC	FRR	WALL THICKNESS*	FRAME	CAVITY	SYSTEM SUMMARY
KIM06	59	-/120/120	188mm	64mm steel frame one side	Minimum 20mm	KOROK® 78mm panels (400 kg/m ³ density) + 1 layer 13mm GIB Noiseline® or equivalent one side + 1 layer 13mm GIB® Standard plasterboard or equivalent other side

*Nominal thickness

KOROK® PANEL

KOROK® 78mm panels are located in KOROK® C-track 60mm high x 80mm wide x 1.15B.M.T. The KOROK® C-track is fixed to the structure at 400mm centres max, and bedded on a bead of fire-rated sealant.

FRAMING

64mm x 34mm x 0.55B.M.T. steel studs, friction fitted into C-Section track 64mm x 30mm x 0.55B.M.T.

Allow a minimum 20mm gap between the framing and the KOROK® panel.

Framing must be installed as per manufacturer's instructions.

ACOUSTIC INSULATION

Acoustic insulation must be either Greenstuf Sound Solution® Plus 75 or Pink® Batts® R1.8 or equivalent within the steel stud side.

LINING

1 layer of 13mm GIB® Standard plasterboard or equivalent on one side and one layer of 13mm GIB Noiseline® or equivalent on the other, fixed vertically with joints over framing one side and direct-fixed the other.

Plasterboard linings are installed to the manufacturer's specification. Joints must be stopped.

SEALANT

Beads of fire-rated sealant are required around the perimeter of the KOROK® system.

Refer to the installation section of this publication for more information on sealant application.

Refer to the KOROK® Components Summary for approved sealants.

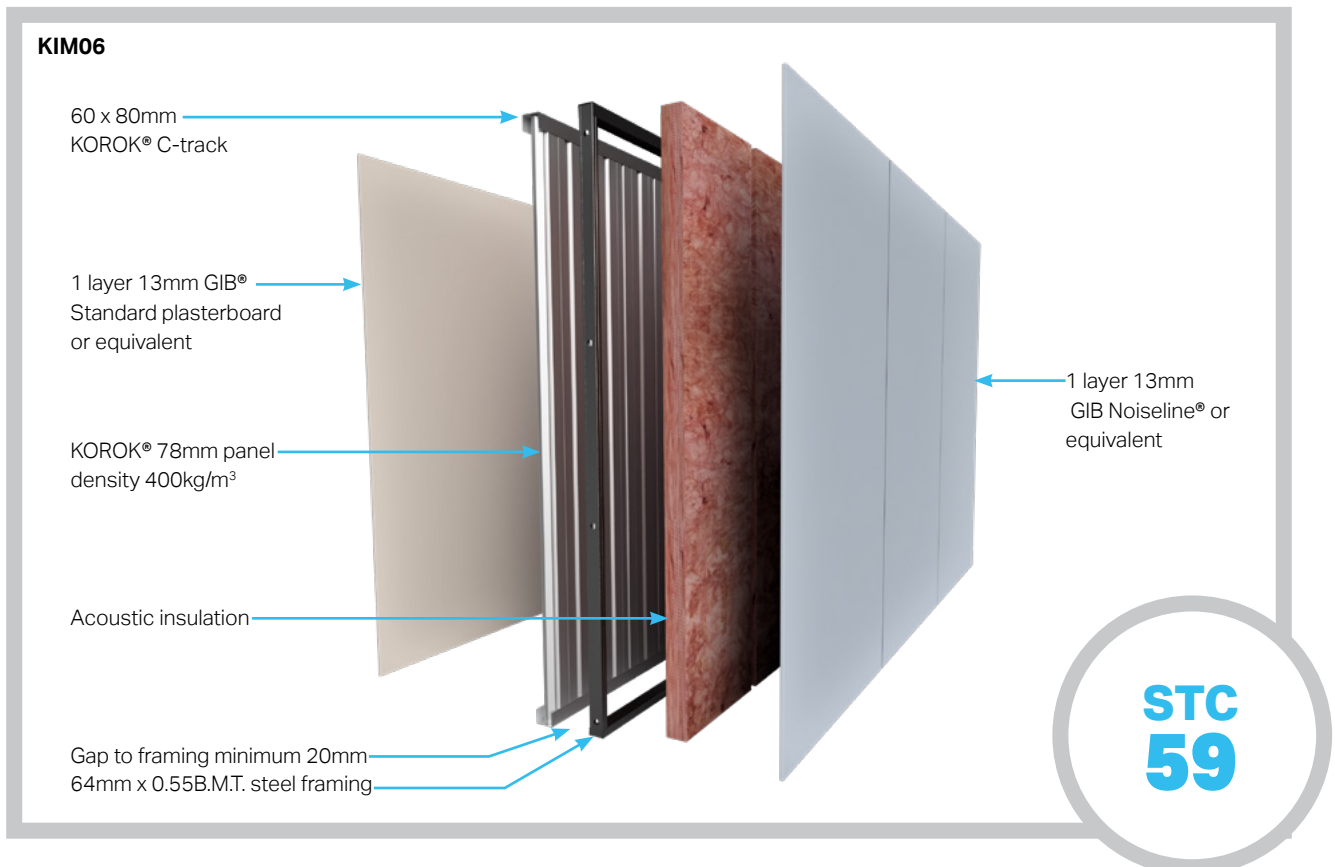

KIM07 FRR -/120/120

SPEC. CODE	STC	FRR	WALL THICKNESS*	FRAME	CAVITY	SYSTEM SUMMARY
KIM07	59	-/120/120	188mm	64mm steel frame one side	Minimum 20mm	KOROK® 78mm panels (400 kg/m ³ density) + 1 layer 13mm GIB® Standard plasterboard or equivalent each side

*Nominal thickness

KOROK® PANEL

KOROK® 78mm panels are located in KOROK® C-track 60mm high x 80mm wide x 1.15B.M.T. The KOROK® C-track is fixed to the structure at 400mm centres max, and bedded on a bead of fire-rated sealant.

FRAMING

64mm x 34mm x 0.55B.M.T. steel studs, friction fitted into C-Section track 64mm x 30mm x 0.55B.M.T.

Allow a minimum 20mm gap between the framing and the KOROK® panel.

Framing must be installed as per manufacturer's instructions.

ACOUSTIC INSULATION

Acoustic insulation must be either Greenstuf Sound Solution® Plus 75 or Pink® Batts® R1.8 or equivalent within the steel stud side.

LINING

1 layer of 13mm GIB® Standard plasterboard or equivalent each side fixed vertically with joints over framing one side and direct-fixed the other.

Plasterboard linings are installed to the manufacturer's specification. Joints must be stopped.

SEALANT

Beads of fire-rated sealant are required around the perimeter of the KOROK® system.

Refer to the installation section of this publication for more information on sealant application.

Refer to the KOROK® Components Summary for approved sealants.

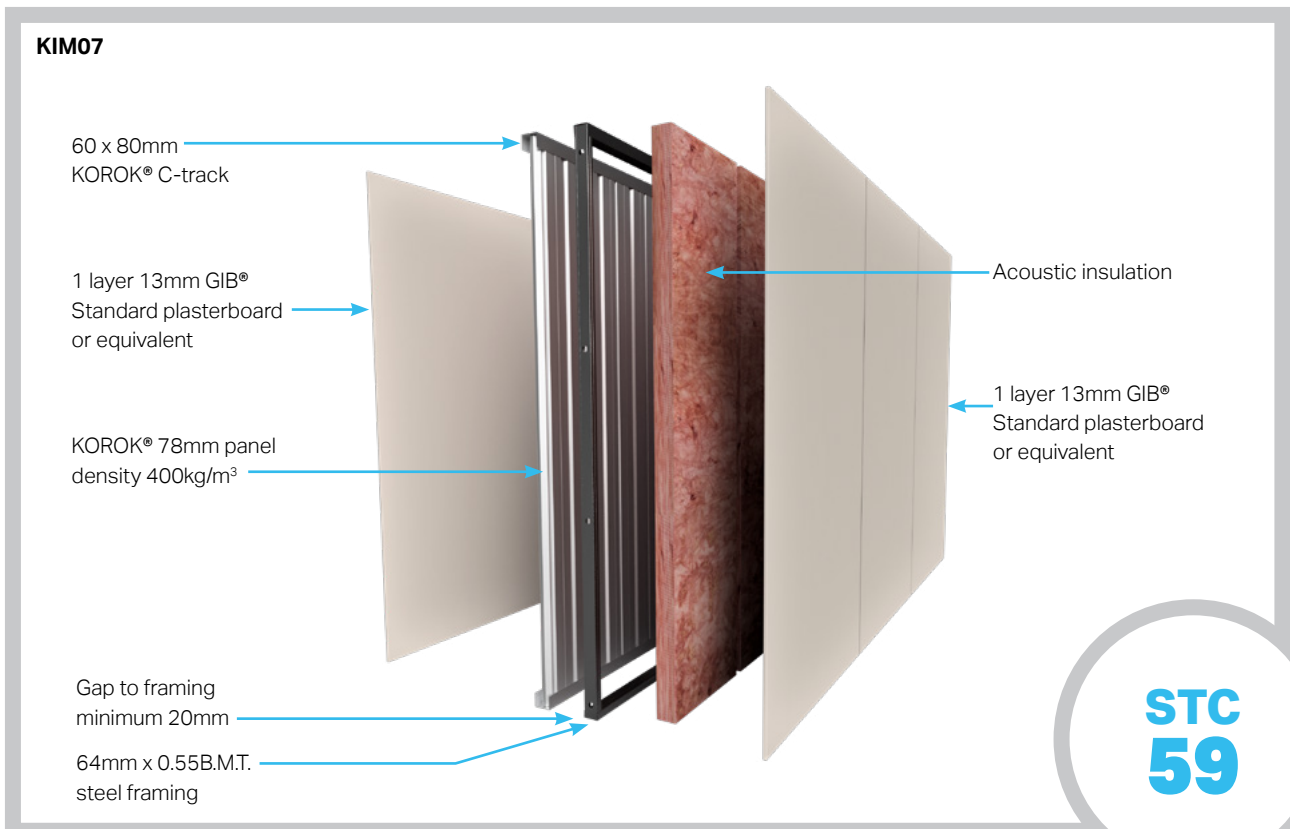

KIM08 FRR -/60/60

SPEC. CODE	STC	FRR	WALL THICKNESS*	FRAME	CAVITY	SYSTEM SUMMARY
KIM08	61	-/60/60	182mm	64mm Steel frame one side. 16mm Furring channel on direct fix clips the other	Minimum 20mm	KOROK® 51mm panels (600 kg/m ³ density) + 1 layer 13mm GIB Noiseline® or equivalent each side

*Nominal thickness

KOROK® PANEL

KOROK® 51mm panels are located in KOROK® C-track 60mm high x 51mm wide x 1.15B.M.T. The KOROK® C-track is fixed to the structure at 400mm centres max, and bedded on a bead of fire-rated sealant. KOROK® panels must not exceed 5 metres in height.

FRAMING

One side, 64mm x 34mm x 0.55B.M.T. steel studs, friction fitted into C-Section track 64mm x 30mm x 0.55B.M.T.

Allow a minimum 20mm gap between the framing and the KOROK® panel.

Other side, 16mm Furring channel at 600mm maximum centres on direct fix clips, fixed to the KOROK® panel at maximum 1000mm centres.

Framing must be installed as per manufacturer's instructions.

ACOUSTIC INSULATION

Acoustic insulation must be Bradford 75mm ACOUSTIGARD 14kg/m³ or equivalent, within the steel stud side.

LINING

1 layer of 13mm GIB Noiseline® or equivalent each side.

Plasterboard linings are installed to the manufacturer's specification. Joints must be stopped.

SEALANT

Beads of fire-rated sealant are required around the perimeter of the KOROK® system.

Refer to the installation section of this publication for more information on sealant application.

Refer to the KOROK® Components Summary for approved sealants.

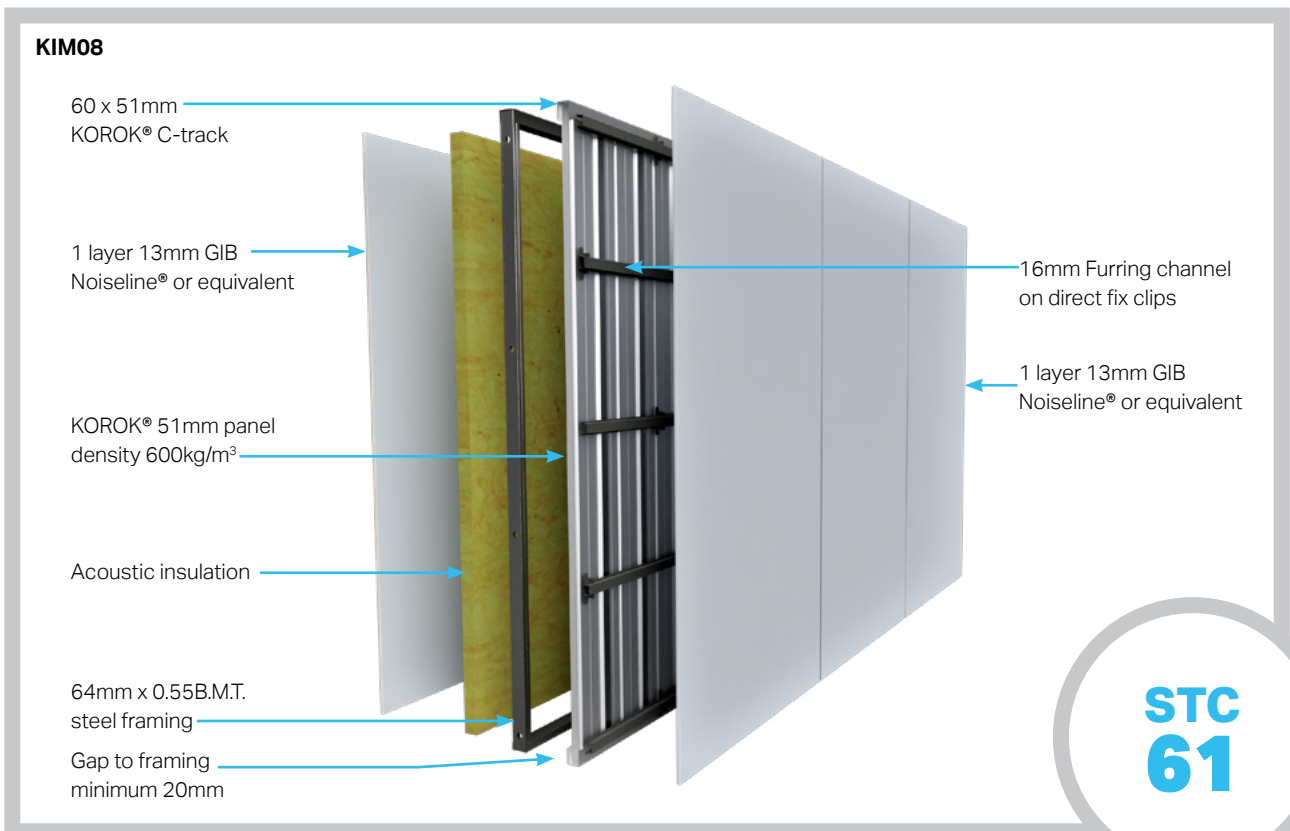

KIM09 FRR -/60/60

SPEC. CODE	STC	FRR	WALL THICKNESS*	FRAME	CAVITY	SYSTEM SUMMARY
KIM09	60	-/60/60	175mm	28mm Furring channel on BETAGRIP® Clips each side	N/A	KOROK® 51mm panels (600 kg/m ³ density) + 1 layer 13mm GIB Noiseline® or equivalent each side

*Nominal thickness

KOROK® PANEL

KOROK® 51mm panels are located in KOROK® C-track 60mm high x 51mm wide x 1.15B.M.T. The KOROK® C-track is fixed to the structure at 400mm centres max, and bedded on a bead of fire-rated sealant. KOROK® panels must not exceed 5 metres in height.

FRAMING

28mm Furring channel at 600mm maximum centres on each side, mounted on BETAGRIP® Clips directly fixed to KOROK® panel at maximum 600mm centres.

Framing must be installed as per manufacturer's instructions.

ACOUSTIC INSULATION

Acoustic insulation must be Pink® Batts® R1.2 50mm 12.8 kg/m³ or equivalent each side.

LINING

1 layer of 13mm GIB Noiseline® or equivalent on each side.

Plasterboard linings are installed to the manufacturer's specification. Joints must be stopped.

SEALANT

Beads of fire-rated sealant are required around the perimeter of the KOROK® system.

Refer to the installation section of this publication for more information on sealant application.

Refer to the KOROK® Components Summary for approved sealants.

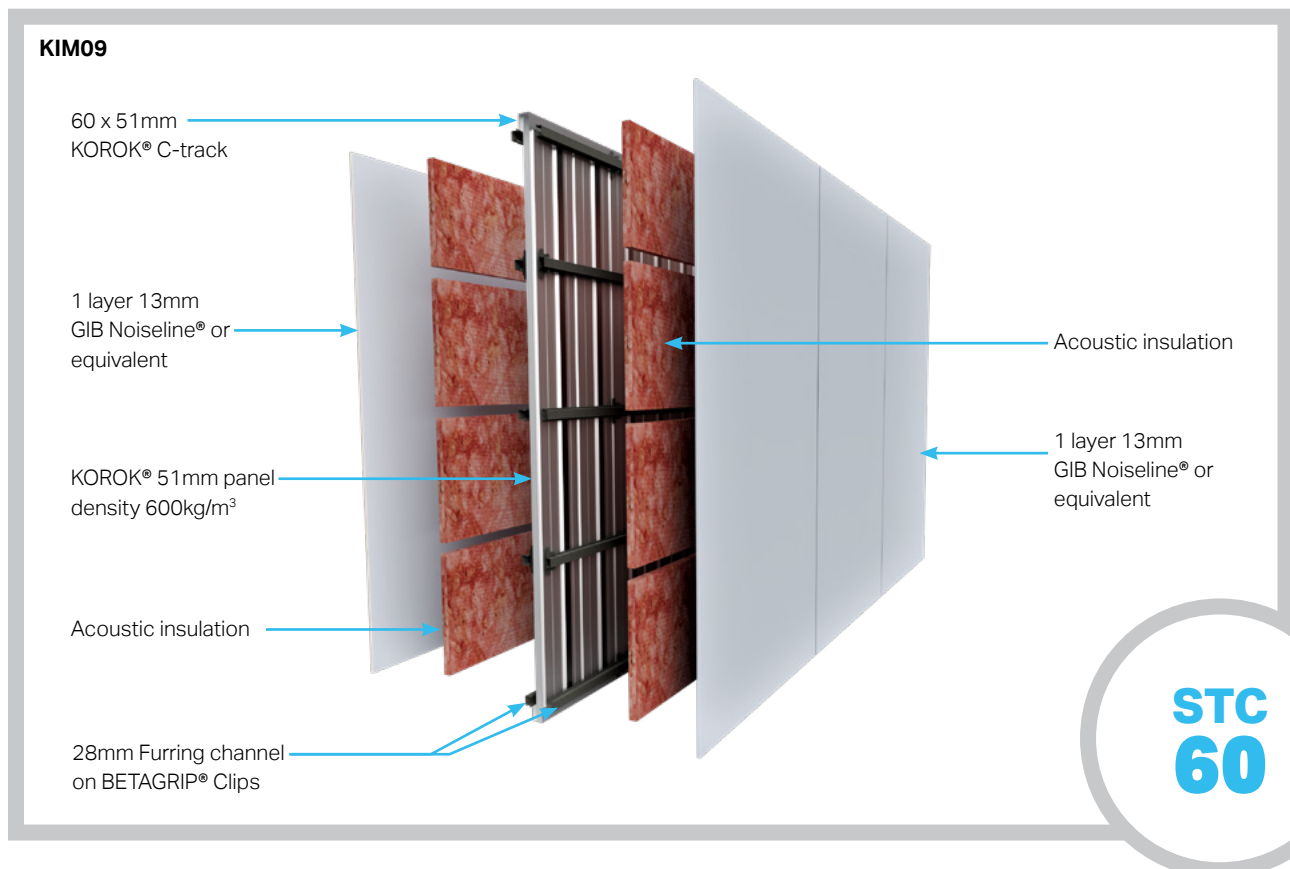

KIM12 FRR -/60/60

SPEC. CODE	STC	FRR	WALL THICKNESS*	FRAME	CAVITY	SYSTEM SUMMARY
KIM12	61	-/60/60	167mm	64mm steel frame one side 16mm Furring channel directly fixed the other	Minimum 10mm	KOROK® 51mm panels (600 kg/m ³ density) + 1 layer 13mm GIB Noiseline® or equivalent each side

*Nominal thickness

KOROK® PANEL

KOROK® 51mm panels are located in KOROK® C-track 60mm high x 51mm wide x 1.15B.M.T. The KOROK® C-track is fixed to the structure at 400mm centres max, and bedded on a bead of fire-rated sealant. KOROK® panels must not exceed 5 metres in height.

FRAMING

64mm x 34mm x 0.55B.M.T. steel studs, friction fitted into C-Section track 64mm x 30mm x 0.55B.M.T.

Allow a minimum 10mm gap between the framing and the KOROK® panel.

16mm Furring channel at 600mm maximum centres on one side directly fixed to KOROK® panel (no clips).

Framing must be installed as per manufacturer's instructions.

ACOUSTIC INSULATION

Acoustic insulation must be Bradford 75mm ACOUSTIGARD 14kg/m³ or equivalent within the steel stud side.

LINING

1 layer of 13mm GIB Noiseline® or equivalent each side.

Plasterboard linings are installed to the manufacturer's specification. Joints must be stopped.

SEALANT

Beads of fire-rated sealant are required around the perimeter of the KOROK® system.

Refer to the installation section of this publication for more information on sealant application.

Refer to the KOROK® Components Summary for approved sealants.

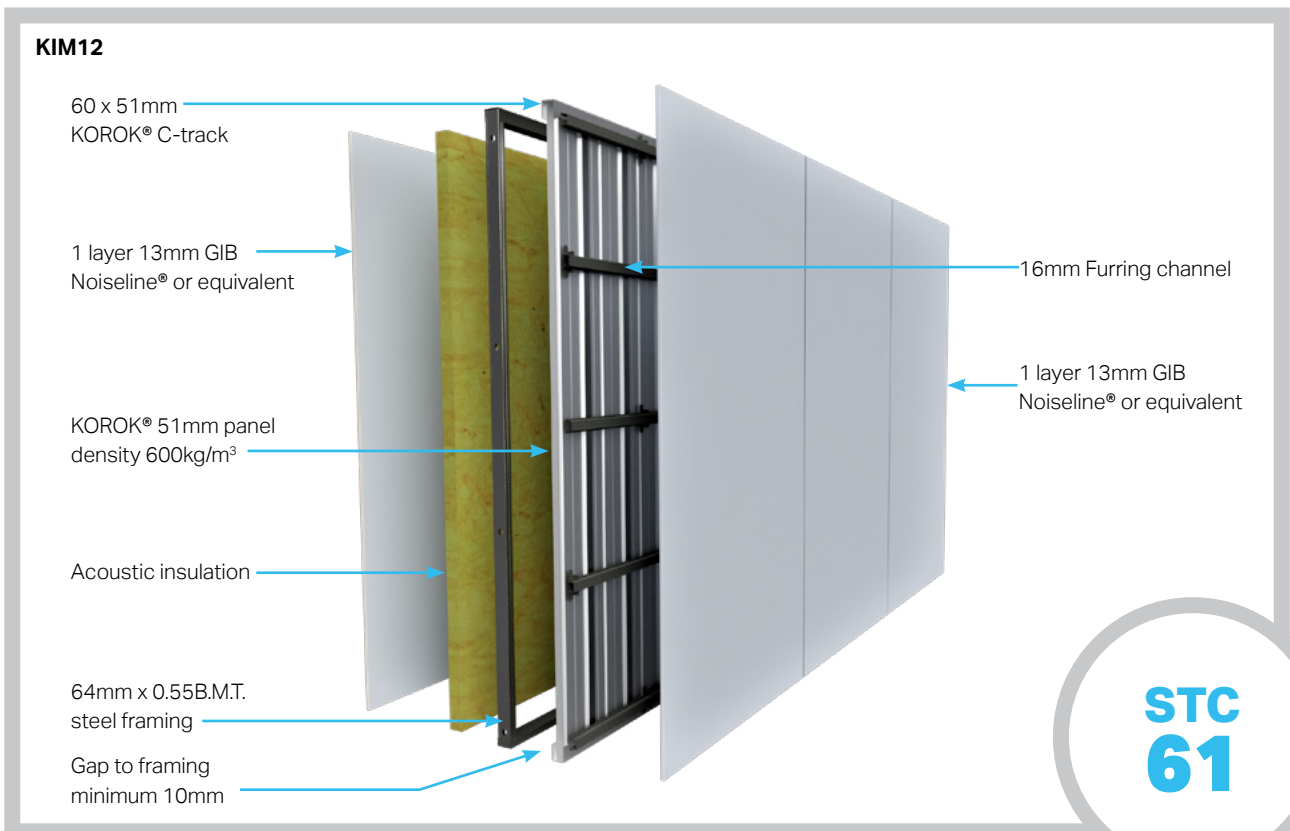

KIM13 FRR -/60/60

SPEC. CODE	STC	FRR	WALL THICKNESS*	FRAME	CAVITY	SYSTEM SUMMARY
KIM13	64	-/60/60	194mm	64mm steel frame one side 16mm Furring channel on 237 direct fix clips the other	Minimum 20mm	KOROK® 51mm panels (600 kg/m ³ density) + 1 layer 13mm GIB Noiseline® or equivalent one side + 2 layers of GIB Noiseline® or equivalent the other side

*Nominal thickness

KOROK® PANEL

KOROK® 51mm panels are located in KOROK® C-track 60mm high x 51mm wide x 1.15B.M.T. The KOROK® C-track is fixed to the structure at 400mm centres max, and bedded on a bead of fire-rated sealant. KOROK® panels must not exceed 5 metres in height.

FRAMING

64mm x 34mm x 0.55B.M.T. steel studs, friction fitted into C-Section track 64mm x 30mm x 0.55B.M.T.

Allow a minimum 20mm gap between the framing and the KOROK® panel.

16mm Furring channel at 600mm maximum centres on the other side mounted on 237 clips fixed to KOROK® panel joints at maximum 1000mm centres.

Framing must be installed as per manufacturer's instructions.

ACOUSTIC INSULATION

Acoustic insulation must be Bradford 75mm ACOUSTIGARD 14kg/m³ or equivalent within the steel stud side.

LINING

1 layer of 13mm GIB Noiseline® or equivalent one side and 2 layers of 13mm GIB Noiseline® or equivalent on the other side.

Plasterboard linings are installed to the manufacturer's specification. Joints must be stopped.

SEALANT

Beads of fire-rated sealant are required around the perimeter of the KOROK® system.

Refer to the installation section of this publication for more information on sealant application.

Refer to the KOROK® Components Summary for approved sealants.

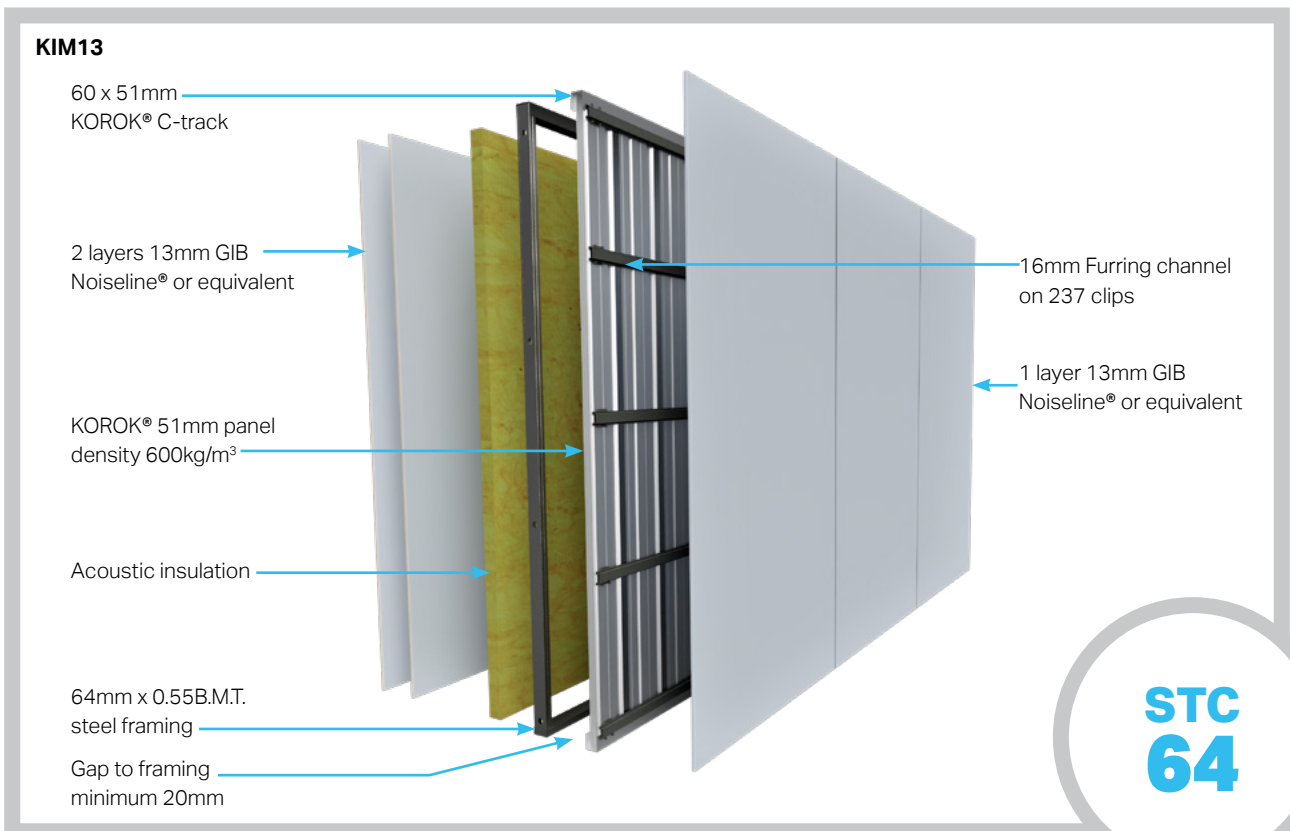

INTERTENANCY APARTMENT SYSTEMS INSTALLATION

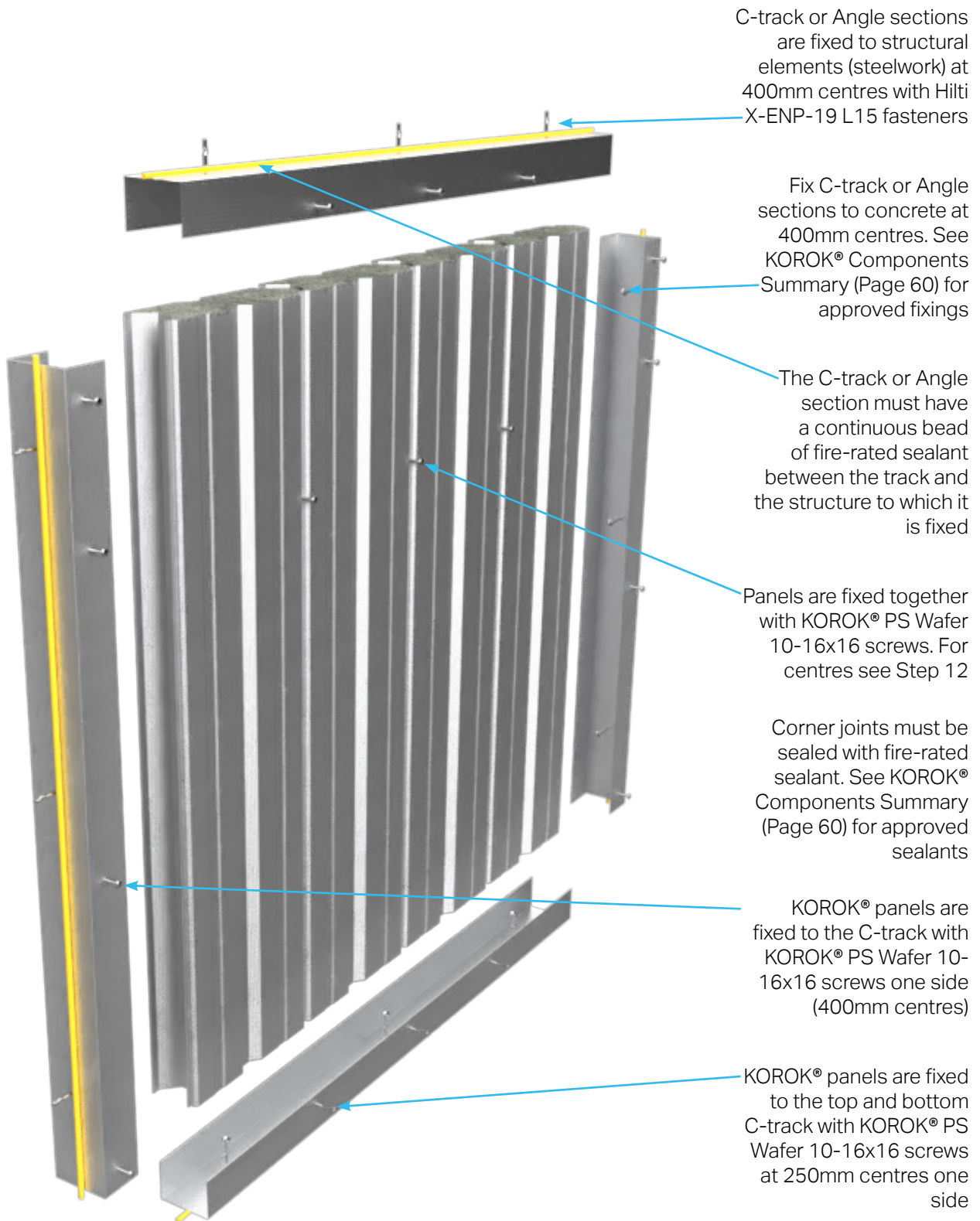

INTERTENANCY APARTMENT SYSTEMS INSTALLATION

VERTICAL INSTALLATION

1 Vertical installation of the KOROK® panels requires the C-track to be fixed to the supporting structure, e.g. walls, columns, portals, soffits and slabs.

Plan your setout.



2 To ensure the C-track is sealed to the structure, a continuous bead of fire-rated sealant is run around the perimeter before the C-track or Angle sections are laid and fixed.

Or the sealant can be applied directly to the C-track before fixing in place.

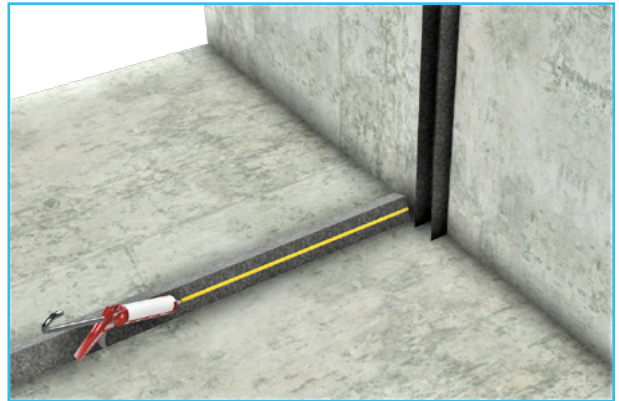

3 Using a masonry drill bit, pre-drill the C-track at 400mm centres.

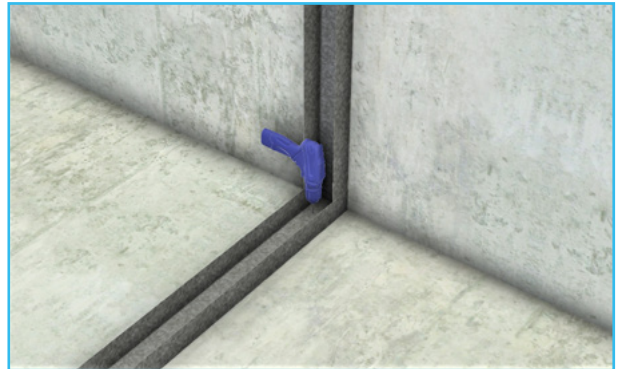

4 Then use the approved fixings to secure the C-track.



INTERTENANCY APARTMENT SYSTEMS INSTALLATION

5 If the surrounding surface is uneven or if you're not sure you have a good seal, add a continuous bead of fire-rated sealant around the perimeter of the C-track where it contacts the surrounding surface.



6 KOROK® panels must be cut 20mm shorter than the structural opening measurement to allow for fitting.

Pull back a 300mm section of the strippable film on the ends of the panels before placing the panels into the C-track.

Ensure that the first panel is plumbed vertical after fitting into the C-track. Screw fix the panel into place to the C-track.

Subsequent panels are placed in a tilt and snap action.

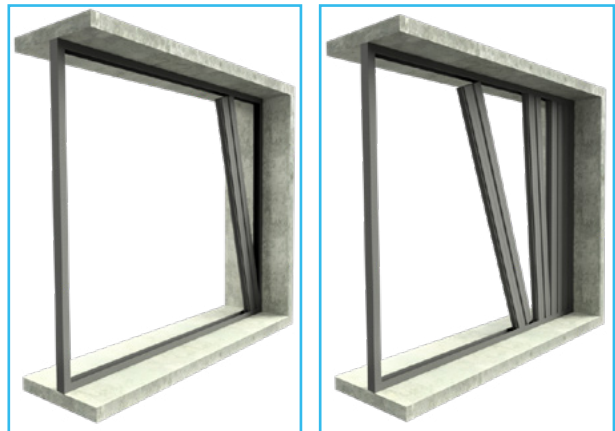

7 Ensure the tongue and groove are fully locked to maintain the fire and acoustic performance. Remove strippable film at the end of each day's work.

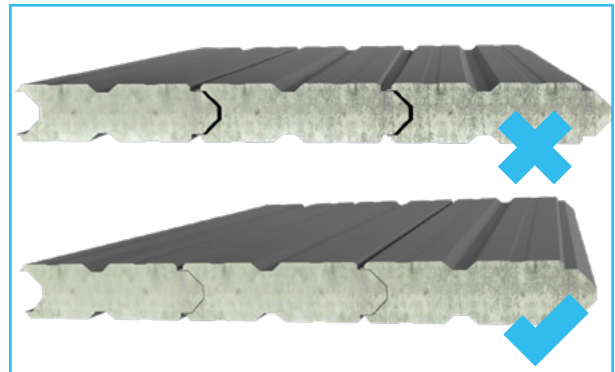

CUTTING OF KOROK® PANELS

8 KOROK® panels can be cut to length and width with the use of a reciprocating saw or a radial saw with dust extraction. Diamond cutting discs are recommended for radial saws.

Where KOROK® panels are trimmed to width, the cut edge of the panel is fitted into the C-track and so is always the last panel abutting the wall or column. The panel is then sealed and fixed in position as usual.

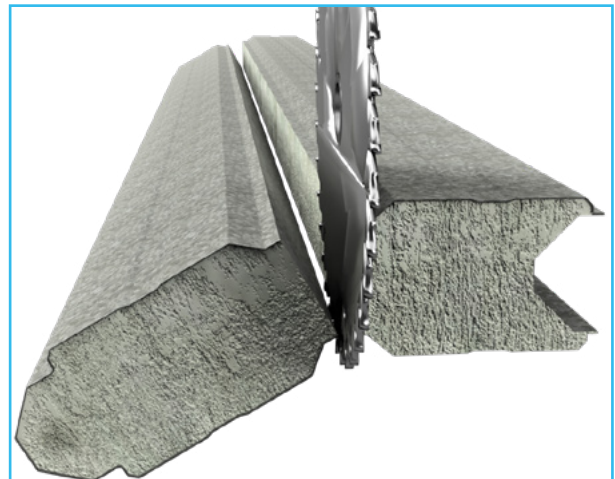

INTERTENANCY APARTMENT SYSTEMS INSTALLATION

LAST PANEL

9 Stop short of the end vertical KOROK® C-track by approximately 1 metre and cut out a 600mm Angle section from the top and bottom C-track.

Plan ahead and make an allowance for a 50mm overlap onto the panels installed prior to the last remaining two panels.

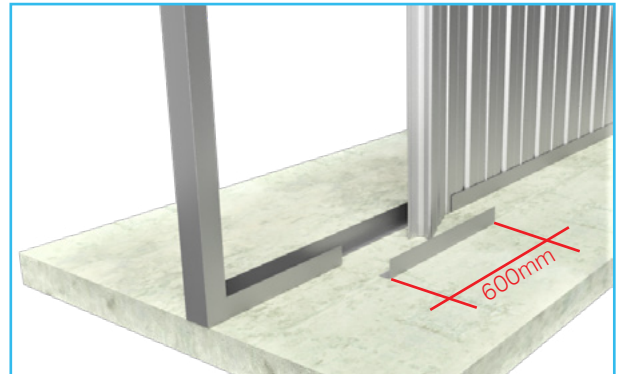

10 Cut your end panel (the last panel) ensuring that a distance of 500mm remains between panels for the last two panels to be squeezed into position.

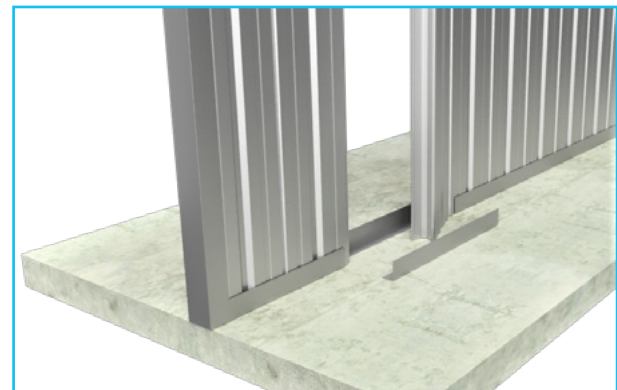

11 Once the final two panels are in position, simply replace the Angle and fix to panels. Screw the C-track and Angle sections to the panels in the normal fashion.



11a When using 51mm KOROK® panels, seal the 3 closed-off panel joints with fire-rated sealant to one side.

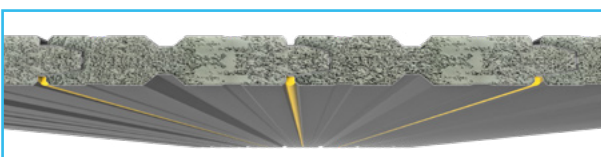

INTERTENANCY APARTMENT SYSTEMS INSTALLATION

12 Panels must be screwed together into every panel joint as per the vertical centres in Table 3 below.

TABLE 3 - FASTENINGS

Panel Thickness (mm)	Panel Orientation	Max. Wall Height (m)	Panel to Panel Max. Centres (mm)	Sides	Notes:
51	Vertical	5m	1000	one	Measured from floor level
78	Vertical	6m	1000	one	Measured from floor level

C-TRACK

C-track is fixed to the KOROK® panels at 400mm centres one side on the vertical C-track and 250mm centres one side on the horizontal C-track.

At corners where two lengths of KOROK® C-track intersect, the two pieces must be fixed to each other with 1 KOROK® PS Wafer 10-16x16 screw.

DEFLECTION C-TRACK DETAILS

Dead and live loads can cause significant deflection in some structures. KOROK® can provide deflection C-track details where deflection loadings are considered.

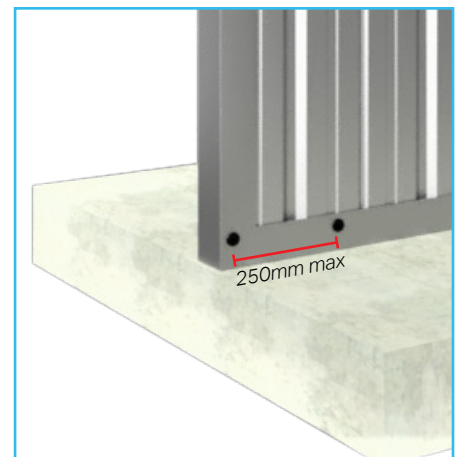
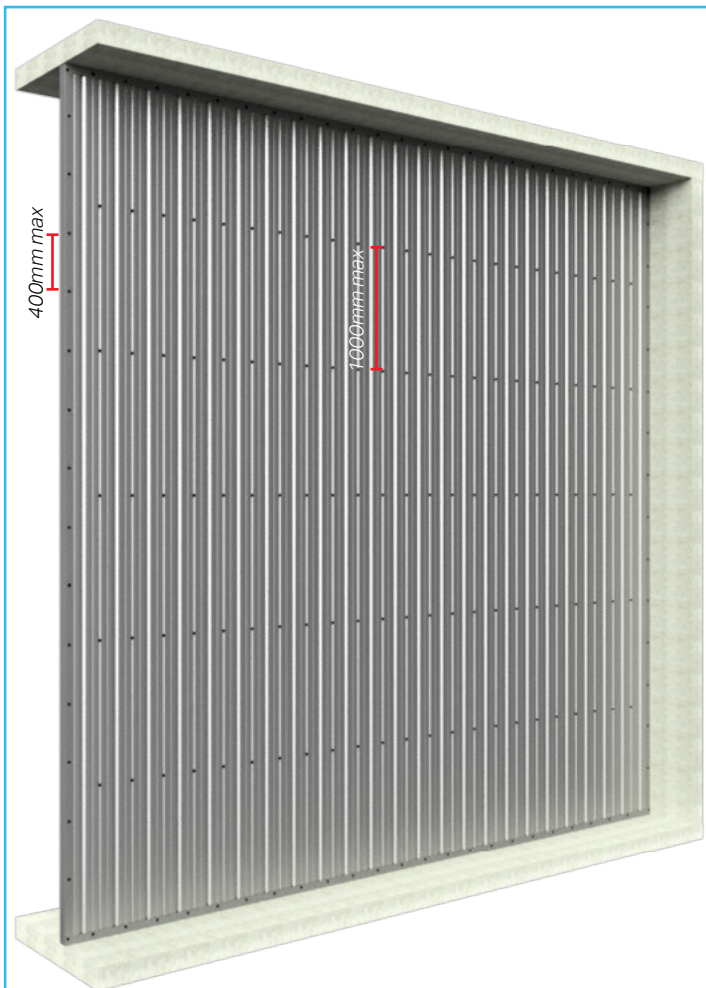

INTERTENANCY APARTMENT SYSTEMS INSTALLATION

13 Remove any remaining plastic film and then apply a continuous bead of fire-rated sealant between the KOROK® C-track and the KOROK® panels as indicated by the yellow line.

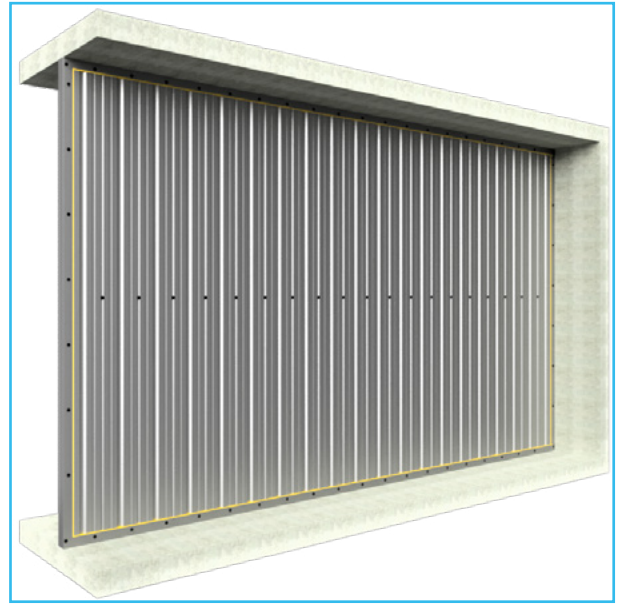

14 Fire-rated sealant details for top and sides.

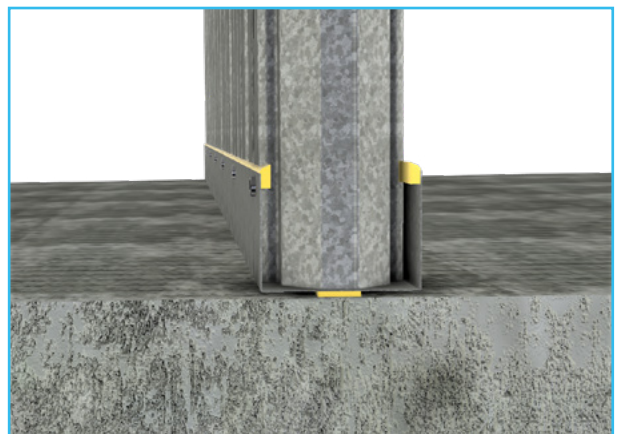
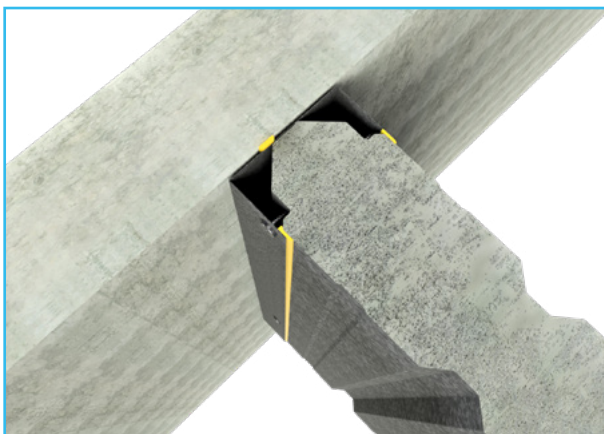
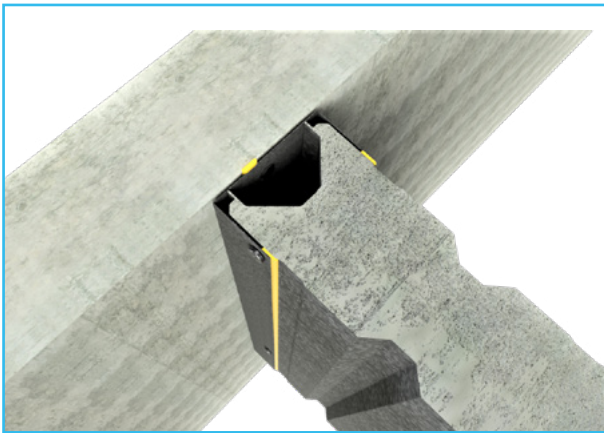

INTERTENANCY APARTMENT SYSTEMS INSTALLATION

15 Using Angle as an alternative to C-track.

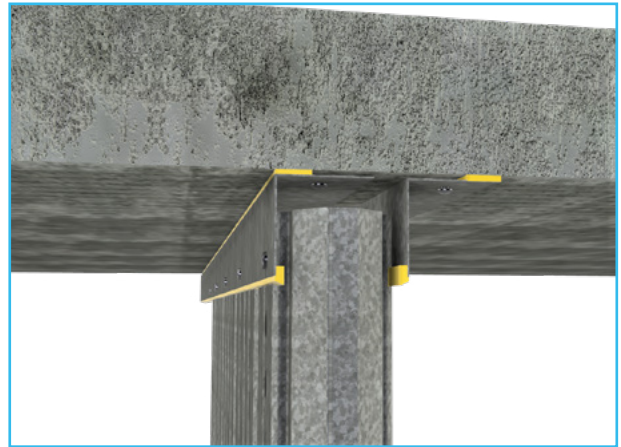

FINAL CHECK

At the completion of the job and at the finish of each day's work, it is essential that the completed area be thoroughly cleaned of all swarf, rivet stems, nails, drillings and screws etc. normally associated with the installation of metal KOROK® panels. Remove any remaining strippable film; check all fixings are correctly installed; check all fire-rated and acoustic-rated sealant is applied correctly.

INTERTENANCY APARTMENT SYSTEMS INSTALLATION

HEAD TRACK PROTECTION

GIB Fyreline® or equivalent PROTECTED HEAD TRACK

GIB Fyreline® or equivalent 13mm x 120mm strip with fire-rated sealant is fixed at 250mm centres top and bottom, using 32mm x 16G drywall screws.

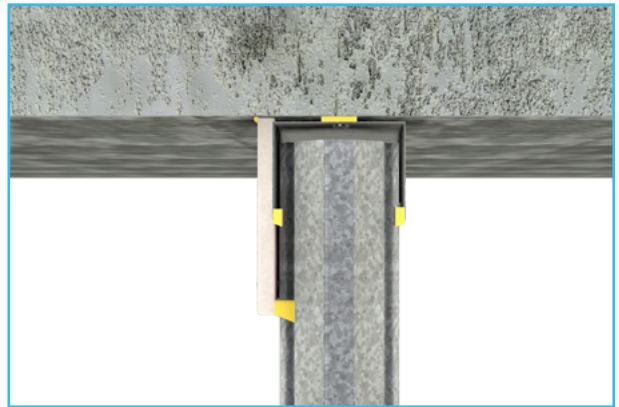
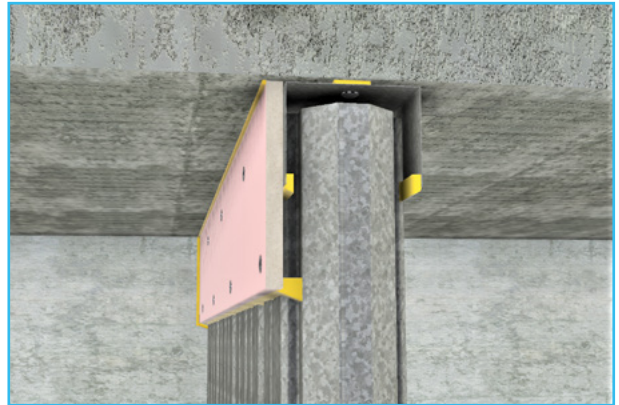

METAL FLASHING PROTECTED HEAD TRACK

KOROK® fire flashing is fixed to the panels at 250mm centres using KOROK® PS Wafer 10-16x16 screws.

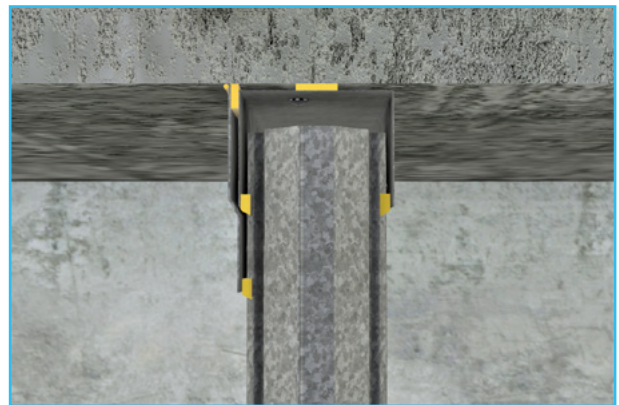

DEFLECTION C-TRACK DETAILS

Dead and live loads can cause significant deflection in some structures.

KOROK® can provide deflection C-track details where deflection loadings are considered.

Contact your KOROK® representative on 0800 773 777 for a solution specific to your project.

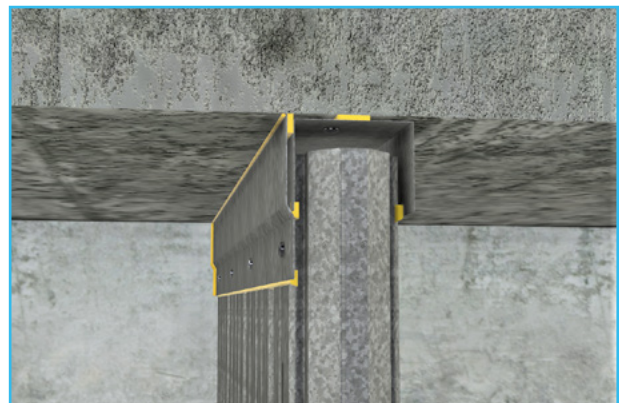

TABLE 4 - KOROK® FASTENERS SPACINGS

Use	Panel Thickness (mm)	Panel Orientation	Maximum Wall Height (m)	Maximum Wall Width (m)	Panel to Panel Maximum centres (mm)	Sides	KOROK® PS Wafer Screw	C-track Perpendicular to Panel (mm)	Panel Face or Joint	Sides of C-track	KOROK® PS Wafer Screw	Notes:
Intertenancy - Apartments	51	Vertical	5m	N/A	1000	one	10-16	250	Face	One	10-16	Measured from floor level
Intertenancy - Apartments	78	Vertical	6m	N/A	1000	one	10-16	250	Face	One	10-16	Measured from floor level

NOTES

- For C-track running parallel to the panels, KOROK® PS Wafer 10-16x16 screw fixings at 400mm centres are used one side.
- 78mm Panel Properties - These span tables are based on ambient conditions. When used as part of a fire-rated system, the maximum unsupported vertical span of the KOROK® panels is 6.0 metres and the maximum unsupported horizontal span is 5.0 metres. Greater spans are subject to specific engineering design and/or fire engineering assessment.
- 51mm Panel Properties - These span tables are based on ambient conditions. When used as part of a fire-rated system, the maximum unsupported span of the KOROK® panels is 5.0 metres vertical or 4.0 metres horizontal. Greater unsupported spans will require specific FRR design.
- Deflection C-track details - Dead and live loads can cause significant deflection in some structures. KOROK® can provide deflection C-track details where deflection loadings are considered.

PANEL PROPERTIES

KOROK® PANELS

KOROK® panels are roll-formed from zinc-coated steel strips. The steel from which the shells are manufactured conforms to AS1397: 2011.

Steel shells have a base metal thickness of 0.4mm B.M.T. with a Z275 zinc coating. These panels have an aerated concrete core and weigh nominally 10.2 kg per lineal metre.

KOROK® panels have 250mm coverage when installed.

LOADING COMBINATIONS

All loading combinations are in accordance with AS/NZS 1170.0:2002.

GENERAL DESIGN NOTES

The tables and charts are prepared for the use of KOROK® in wall applications i.e. floor systems cannot be modelled from the safe load tables in this manual. Interpolation of the tables is acceptable.

MANUFACTURERS' DOCUMENTS

Refer to KOROK® Systems Manuals.

- GreenStuf® Insulation Data Sheets
- GIB® Site Guide
- GIB® Fire Rated Systems
- Penetrations and closures in GIB® Fire Rated Systems
- GIB® Noise Control Systems
- Hilti® New Zealand Technical Manual
- Pink® Batts® Data Sheets
- Powers Fasteners Specification & Design Manual
- Rondo® Steel Stud & Tracks Installation Manual

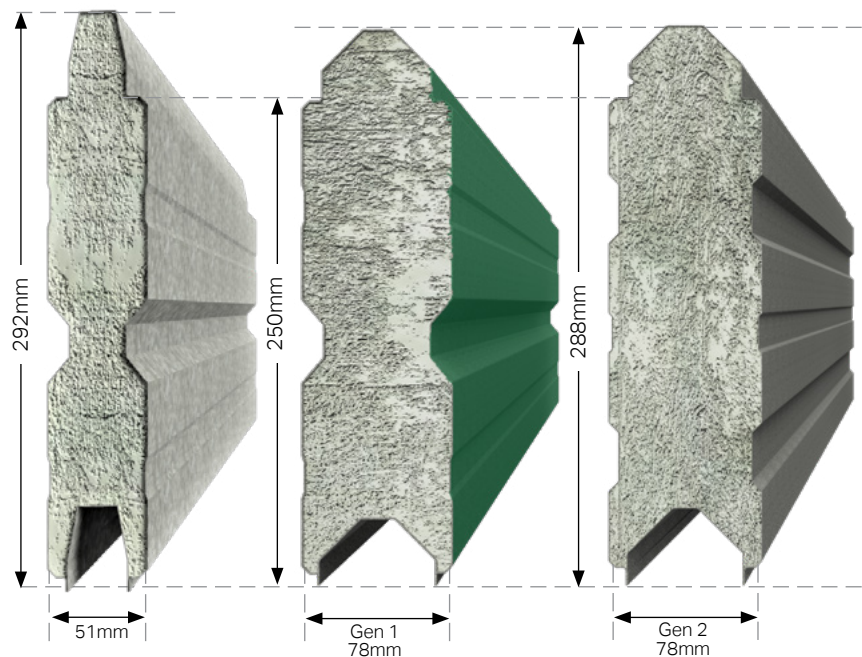

KOROK® PANEL PROPERTIES: 78MM 400KG/M³

KOROK® PANEL PROPERTIES

- Base Metal Thickness 0.4mm B.M.T.
 - Mass kg per lineal metre 10.2 nominal
 - Mass kg/m² 40.8 nominal
- EI** 60 kNm² per panel (*bending stiffness, minor axis*)
- EI** 387 kNm² per panel (*bending stiffness, major axis*)
- EA** 4060 kN per panel (*axial stiffness*)
- GJ** 583 kNm² per panel (*torsional stiffness*)

VERTICAL SPAN WALLS

- Maximum bending moment / panel 1.43 kNm (ULS)
- Maximum axial end crush force / panel 25 kN (ULS)
3.4 kN (SLS)
- Maximum horizontal reaction (crushing on flat) / panel
8.9 kN (ULS) 3.1 kN (SLS)

HORIZONTAL SPAN WALLS

- Maximum bending moment / panel 1.43 kNm (ULS)
- Maximum axial edge crush force per unit length
17 kN/m (ULS) 6k N/m (SLS)
- Maximum horizontal reaction / panel 8.9 kN (ULS)
3.1 kN (SLS)

THERMAL RESISTANCE

- R Value 0.30 (m²K)/W
- U Value 3.2 W/(m²K)

DEFINITIONS

ULS: Value shown is for Ultimate Limit State loading

SLS: Value shown is for Serviceability Limit State loading

USE OF TABLES

1. These Span Tables are based on ambient conditions.
2. When used as part of a fire-rated system, the maximum unsupported vertical span of the KOROK® 78mm panel is 6.0 metres. The maximum unsupported horizontal span of the KOROK® 78mm panel is 5.0 metres. Greater spans or walls where additional load carrying capacity is required are subject to specific engineering design and/or fire engineering assessment.

3. Shelf loading requires specific engineering design.
4. Determine the loads on the KOROK® wall in accordance with AS/NZS 1170.0.
5. Use **Table 6 - Horizontal Span** to ensure that walls spanning horizontally can carry the loads previously calculated. Use **Table 7 - Vertical Span** to ensure that walls spanning vertically can carry the loads previously calculated. Interpolation of points in the tables is allowed.
6. The Tables have been generated for a range of deflection limits i.e. Span/150, Span/200, Span/250, Span/300 in both the vertical and horizontal KOROK® panel configurations.
7. The walls must be checked for both ultimate limit state (ULS) loading and serviceability limit state (SLS) loading.
8. Vertical Span Tables have been generated to a maximum unsupported span of 8.0 metres height.
9. Horizontal Span Tables have been generated based on a 14.0 metres high wall.
10. For horizontal panel unsupported spans over 5.0 metres, for maximum wall heights please contact us at KOROK® on 0800 773 777.

DEFLECTION C-TRACK DETAILS

Dead and live loads can cause significant deflection in some structures.

KOROK® can provide deflection C-track details where deflection loadings are considered.

Contact your KOROK® representative on 0800 773 777 for a solution specific to your project.

SUPPORTING STRUCTURES

KOROK® walls must be supported. The supporting structures themselves must be specifically designed to carry the load of the KOROK® walls.

The fastener strengths shown in this section may be used to design the connections. Maximum spacing of fasteners is shown on installation information.

INSTALLATION NOTE

All KOROK® C-track to structure, KOROK® C-track to KOROK® panel, and KOROK® panel to KOROK® panel connections shall be in accordance with details specified in this manual unless specified otherwise by the Project Engineer.

KOROK® PANEL PROPERTIES: 78MM 400KG/M³

TABLE 5 - SHEAR STRENGTH PER FASTENER FOR THE FOLLOWING CONNECTIONS

CONNECTION	LOAD DIRECTION	TYPE	DESIGN STRENGTH (KN) ULS	DESIGN STRENGTH (KN) SLS
Panel to panel	In-plane	10x16 galvanised Steeltite wafer head screws	1.01	0.83
Panel sides to C-track	In-plane	10x16 galvanised Steeltite wafer head screws	0.95	0.78
Panel sides to C-track	Out-of-plane	10x16 galvanised Steeltite wafer head screws	0.91	0.74
Panel ends to C-track	In-plane	10x16 galvanised Steeltite wafer head screws	0.91	0.74
Panel ends to C-track	Out-of-plane	10x16 galvanised Steeltite wafer head screws	2.21	0.77
C-track to concrete	In-plane	6.5x32 Rawl Mushroom spikes	7.84	2.27
C-track to concrete	Out-of-plane	6.5x32 Rawl Mushroom spikes	7.84	2.27
C-track to steel support	In-plane	Hilti® X-ENP-10 L15 Nails	4.32	2.31
C-track to steel support	Out-of-plane	Hilti® X-ENP-10 L15 Nails	4.32	2.31
KOROK® aluminium bracket to panel joint	Out-of-plane	Hex Head Type 17 14g x 35mm screws	0.92	0.92

TABLE 6 - HORIZONTAL SPAN

SPAN (M)	ULS DESIGN	SLS DESIGN L/150	SLS DESIGN L/200	SLS DESIGN L/250	SLS DESIGN L/300
2	10.05		9	7.7	6.7
2.5	7.3	6.02	4.94	4.2	3.64
3	5.04	3.7	3	2.5	2.17
3.5	3.7	2.42	1.95	1.63	1.39
4	2.82	1.67	1.34	1.1	0.94
4.5	1.94	1.19	0.94	0.78	0.66
5	1.37	0.88	0.69	0.56	0.47
6	0.72	0.51	0.39	0.32	0.26
7	0.38	0.31	0.23	0.19	0.15
8	0.17	0.17	0.14	0.11	0.09

Maximum pressure that can be resisted by a horizontal span (kPa)

Horizontal Span Table has been generated based on a 14m high wall.

For unsupported horizontal spans over 5.0m please contact us at KOROK® on 0800 773 777 for maximum wall heights.

TABLE 7 - VERTICAL SPAN

SPAN (M)	ULS DESIGN	SLS DESIGN L/150	SLS DESIGN L/200	SLS DESIGN L/250	SLS DESIGN L/300
2	10.05		9.05	7.75	6.77
2.5	7.3	6.05	4.95	4.2	3.64
3	5.04	3.7	3	2.53	2.18
3.5	3.7	2.42	1.96	1.64	1.4
4	2.82	1.68	1.34	1.12	0.95
4.5	2.23	1.21	0.96	0.79	0.67
5	1.79	0.9	0.71	0.58	0.49
6	1.22	0.54	0.42	0.34	0.28
7	0.89	0.34	0.26	0.21	0.17
8	0.66	0.23	0.17	0.14	0.11

Maximum pressure that can be resisted by a vertical span (kPa)

Vertical Span Table has been generated to a maximum of 8m wall height. Length of the wall is not a consideration when calculating span.

KOROK® PANEL PROPERTIES: 51MM 600KG/M³

KOROK® PANEL PROPERTIES

- Base Metal Thickness 0.4mm B.M.T.
 - Mass kg per lineal metre 10.1 nominal
 - Mass kg/m² 40.4 nominal
- EI** 24 kNm² per panel (*bending stiffness, minor axis*)
- EI** 400 kNm² per panel (*bending stiffness, major axis*)
- EA** 4060 kN per panel (*axial stiffness*)
- GJ** 27 kNm² per panel (*torsional stiffness*)

VERTICAL SPAN WALLS

- Maximum bending moment / panel 0.96 kNm (ULS)
- Maximum axial end crush force / panel 32 kN (ULS)
2.9 kN (SLS)
- Maximum horizontal reaction (crushing on flat) / panel
1.08 kN (ULS) 0.93 kN (SLS)

HORIZONTAL SPAN WALLS

- Maximum bending moment / panel 0.96 kNm (ULS)
- Maximum axial edge crush force per unit length
5.5 kN/m (ULS) 0.77 kN/m (SLS)
- Maximum horizontal reaction / panel 1.08 kN (ULS)
0.93 kN (SLS)

DEFINITIONS

ULS: Value shown is for Ultimate Limit State loading

SLS: Value shown is for Serviceability Limit State loading

USE OF TABLES

1. These Span Tables are based on ambient conditions.
2. When used as part of a fire-rated system, the maximum unsupported vertical span of the KOROK® 51mm panel is 5.0 metres. The maximum unsupported horizontal span of the KOROK® 51mm panel is 4.0 metres. Greater spans or walls where additional load carrying capacity is required are subject to specific engineering design and/or fire engineering assessment.
3. Shelf loading requires specific engineering design.
4. Determine the loads on the KOROK® wall in accordance with AS/NZS 1170.0.

5. Use **Table 9 - Horizontal Span** to ensure that walls spanning horizontally can carry the loads previously calculated. Use **Table 10 - Vertical Span** to ensure that walls spanning vertically can carry the loads previously calculated. Interpolation of points in the tables is allowed.
6. The Tables have been generated for a range of deflection limits i.e. Span/150, Span/200, Span/250, Span/300 in both the vertical and horizontal KOROK® panel configurations.
7. The walls must be checked for both ultimate limit state (ULS) loading and serviceability limit state (SLS) loading.
8. Vertical Span Tables have been generated to a maximum unsupported span of 5.0 metres height.
9. Horizontal Span Tables have been generated based on a 5.0 metres high wall.
10. For horizontal panel unsupported spans over 4.0 metres, for maximum wall heights please contact us at KOROK® on 0800 773 777.

DEFLECTION C-TRACK DETAILS

Dead and live loads can cause significant deflection in some structures.

KOROK® can provide deflection C-track details where deflection loadings are considered.

Contact your KOROK® representative on 0800 773 777 for a solution specific to your project.

SUPPORTING STRUCTURES

KOROK® walls must be supported. The supporting structures themselves must be specifically designed to carry the load of the KOROK® walls.

The fastener strengths shown in this section may be used to design the connections. Maximum spacing of fasteners is shown on installation information.

INSTALLATION NOTE

All KOROK® C-track to structure, KOROK® C-track to KOROK® panel, and KOROK® panel to KOROK® panel connections shall be in accordance with details specified in this manual unless specified otherwise by the Project Engineer.

KOROK® PANEL PROPERTIES: 51MM 600KG/M³

TABLE 8 - SHEAR STRENGTH PER FASTENER FOR THE FOLLOWING CONNECTIONS

CONNECTION	LOAD DIRECTION	TYPE	DESIGN STRENGTH (KN) ULS	DESIGN STRENGTH (KN) SLS
Panel to panel	In-plane	10x16 galvanised Steeltite wafer head screws	1.01	0.83
Panel sides to C-track	In-plane	10x16 galvanised Steeltite wafer head screws	0.95	0.78
Panel sides to C-track	Out-of-plane	10x16 galvanised Steeltite wafer head screws	0.91	0.74
Panel ends to C-track	In-plane	10x16 galvanised Steeltite wafer head screws	0.91	0.74
Panel ends to C-track	Out-of-plane	10x16 galvanised Steeltite wafer head screws	2.21	0.77
C-track to concrete	In-plane	6.5x32 Rawl Mushroom spikes	7.84	2.27
C-track to concrete	Out-of-plane	6.5x32 Rawl Mushroom spikes	7.84	2.27
C-track to steel support	In-plane	Hilti® X-ENP-10 L15 Nails	4.32	2.31
C-track to steel support	Out-of-plane	Hilti® X-ENP-10 L15 Nails	4.32	2.31
KOROK® aluminium bracket to panel joint	Out-of-plane	Hex Head Type 17 14g x 35mm screws	0.92	0.92

TABLE 9 - HORIZONTAL SPAN

SPAN (M)	ULS DESIGN	SLS DESIGN L/150	SLS DESIGN L/200	SLS DESIGN L/250	SLS DESIGN L/300
2	7.66		6.22	4.98	4.15
2.5	4.90	4.25	3.18	2.55	2.12
3	3.40	2.46	1.84	1.47	1.23
3.5	2.50	1.55	1.16	0.93	0.77
4	1.91	1.04	0.78	0.62	0.52

Maximum pressure that can be resisted by a horizontal span (kPa)
For horizontal panel, the maximum unsupported span is 4m.

Unsupported horizontal wall spans greater than 4m are subject to specific design.

TABLE 10 - VERTICAL SPAN

SPAN (M)	ULS DESIGN	SLS DESIGN L/150	SLS DESIGN L/200	SLS DESIGN L/250	SLS DESIGN L/300
2	7.66		6.22	4.98	4.15
2.5	4.90	4.25	3.18	2.55	2.12
3	3.40	2.46	1.84	1.47	1.23
3.5	2.50	1.55	1.16	0.93	0.77
4	1.91	1.04	0.78	0.62	0.52
4.5	1.51	0.73	0.55	0.44	0.36
5	1.22	0.53	0.40	0.32	0.27

Maximum pressure that can be resisted by a vertical span (kPa)
The length of the wall is not a consideration when calculating span.

INTERTENANCY APARTMENT DEFLECTION HEAD DETAILS

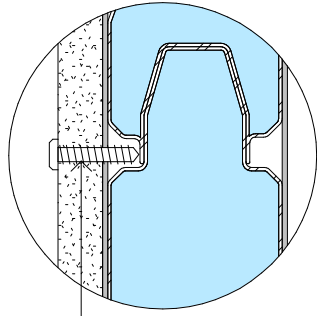

Fire Rated Plasterboard 13mm strip x 120mm wide fixed to the KOROK® C-track with pairs of 10g x 22mm screw fixings at 250mm centres. Screw location in line with the 250mm vertical KOROK® panel joints

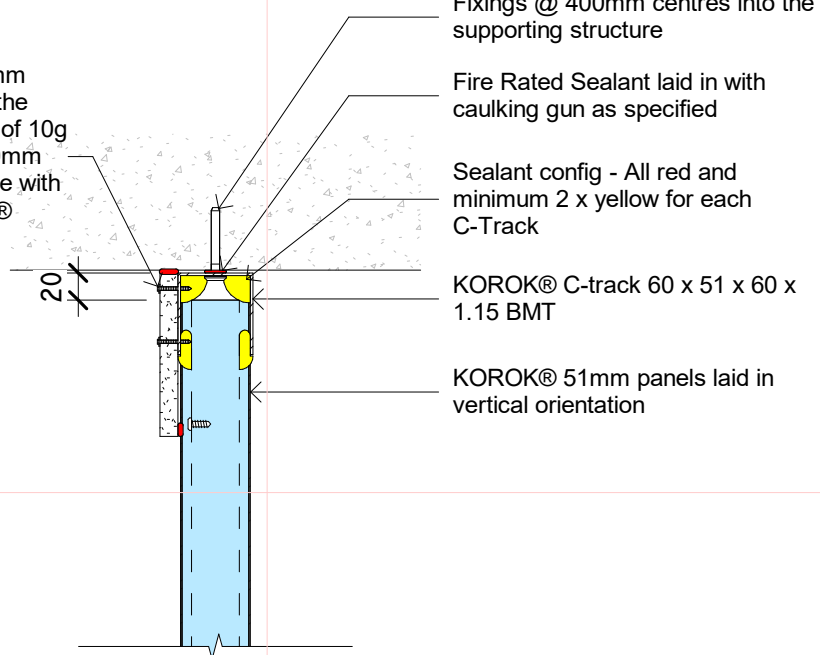

Where the fire rated junction is included in a fire separation wall, refer to the fire protection designer for the FRR of the wall

Fixings @ 400mm centres into the supporting structure

Fire Rated Sealant laid in with caulking gun as specified

Sealant config - All red and minimum 2 x yellow for each C-Track

KOROK® C-track 60 x 51 x 60 x 1.15 BMT

KOROK® 51mm panels laid in vertical orientation

Fire Rated Plasterboard 13mm Strip x 120mm wide fixed to the KOROK® Top track with pairs of 6g x 22mm screw fixings at 250mm centres. Screw location in line with the 250mm vertical KOROK® panel joints

KOROK® C-track 60 x 51 x 60 1.15 BMT

Note: When omitting screws from the top C-track 10g x 16mm screw fixings are to be placed into the KOROK® panel joints, nominally 50mm below the KOROK® C-Track one side only

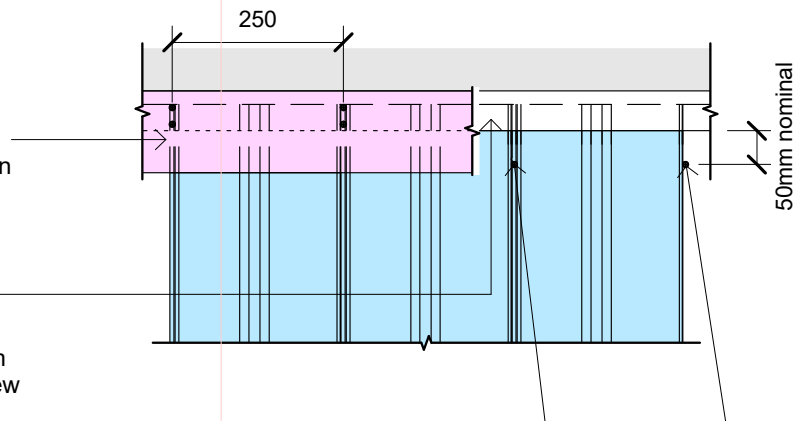

INTERTENANCY APARTMENT DEFLECTION HEAD DETAILS

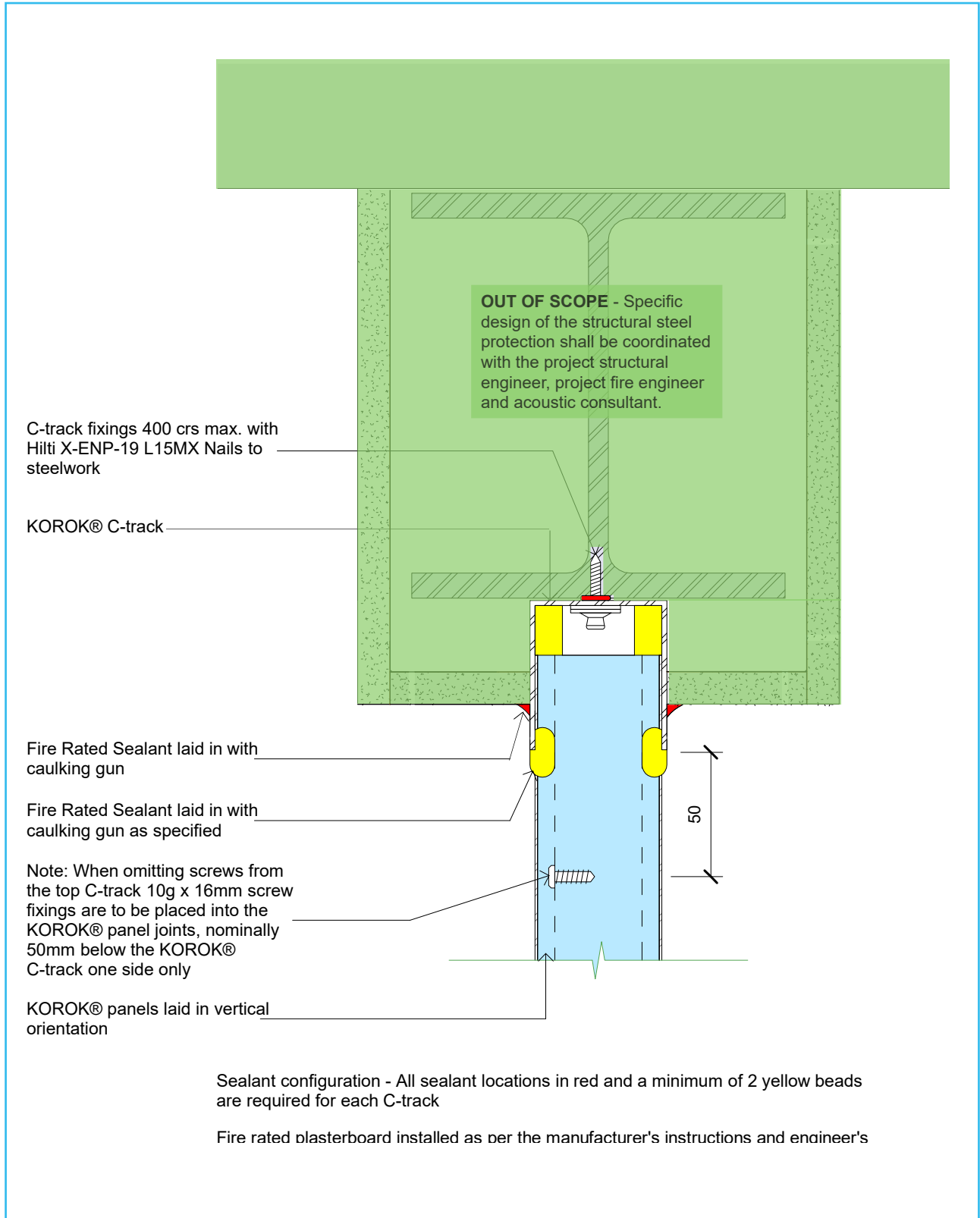



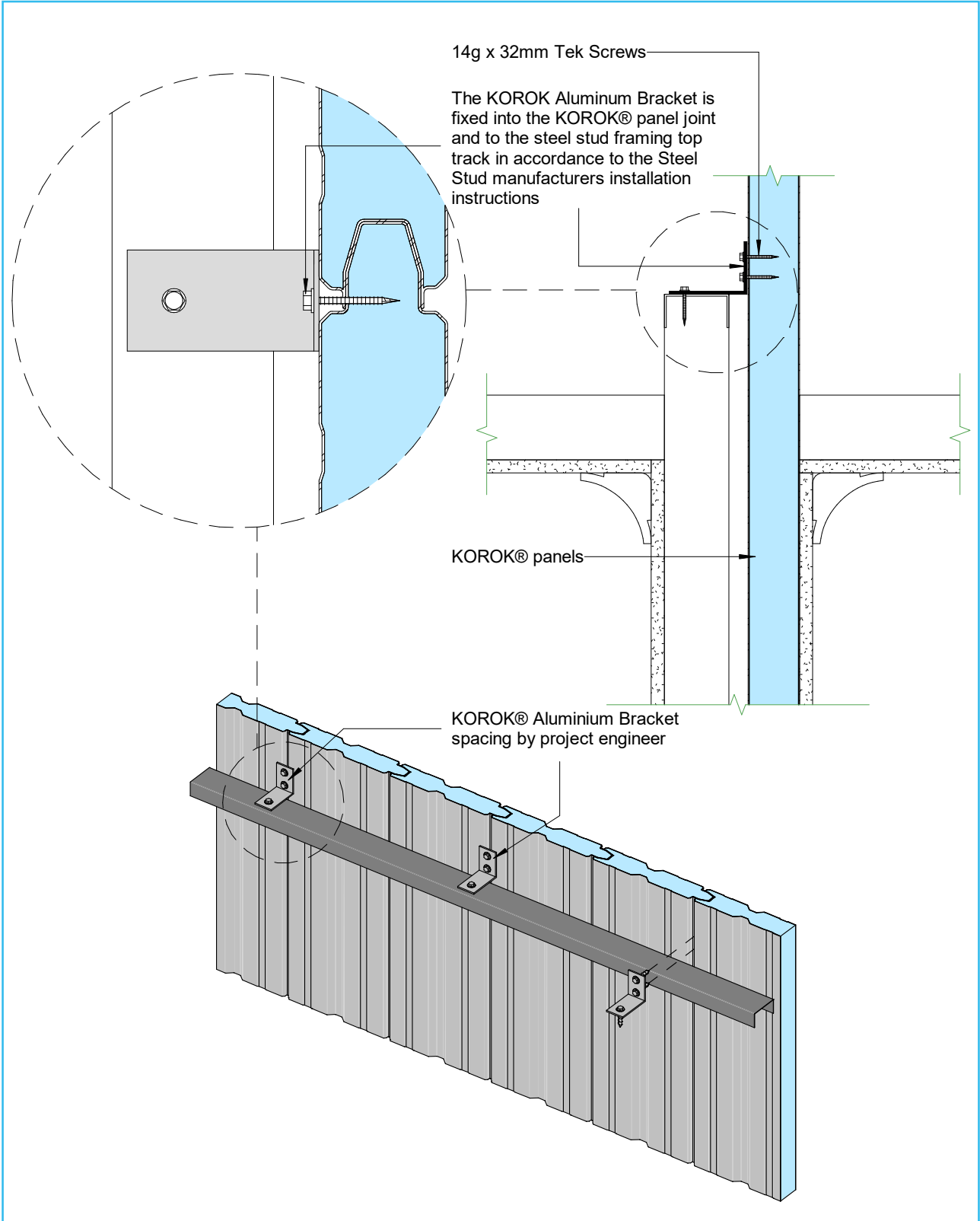



INTERTENANCY APARTMENT BRACKET DETAIL



KOROK® COMPONENTS SUMMARY

PRODUCT IMAGE	ITEM DESCRIPTION
	PN1159 KOROK® C-track 60 x 51 x 60mm 1.15B.M.T.
	PN1140 KOROK® C-track 60 x 80 x 60mm 1.15B.M.T.
	PN1122 KOROK® panel 51mm wide 250mm cover 600kg/m³ density
	PN1130 KOROK® panel 78mm wide 250mm cover 400 kg/m³ density (Colour)
	PN1318 KOROK® GEN 2 panel 78mm wide 250mm cover 400 kg/m³ density (Galvanised)
	PN1310 Hilti HUS3-P 6 Concrete screw anchor
	PN1343 Hilti HUS3-H 6 Concrete screw anchor
	PN1185 Hilti DBZ 6/4.5 x 32mm
	PN1190 6.5 x 32 Rawl Mushroom spikes

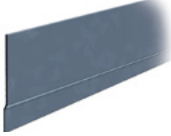
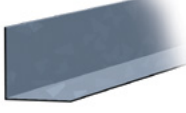
PRODUCT IMAGE	ITEM DESCRIPTION
	PN1170 KOROK® PS Wafer 10-16x16 Class 3
	PN1171 KOROK® PS Wafer 10-16x30 Class 3
	PN1157 KOROK® MS Fire Seal
	PN1161 KOROK® Acrylic Fire Seal
	PN1165 Sikaflex-400 Fire Rated Sealant
	PN1160 Hilti CP606
	PN1198 Hex Head Type 17 14g x 35mm screws
	PNAB10 Aluminium Bracket 75x50x3mm
	PN1226 KOROK® fire flashing
	PN1150 KOROK® Angle

SUSTAINABILITY

KOROK® is a high performance product with minimal impact on the planet

KOROK® is made to order, ensuring minimal onsite waste

KOROK® is fully re-usable

KOROK® is fully recyclable

KOROK® is manufactured in NZ

Declare.

KOROK panel
KOROK Building Systems NZ Ltd

Final Assembly: Hamilton, New Zealand
Life Expectancy: 50 Year(s)
Embodied Carbon: 58.87 kg CO₂-eq
Declared Unit: 1 M2
End of Life Options: Salvageable/Reusable in its Entirety, Recyclable (100%)

Ingredients:

Inner Core: Portland Cement; Water; **Fly Ash**; Washed Fine Sand; Anionic Detergent Blend (0.01%); Nonionic Surfactant; Polypropylene Filaments; **Outer Steel Shell**: Low Carbon Steel; Antimony; Zinc

LBC Temp Exception RL-004b - Proprietary Ingredients in Declare

Living Building Challenge Criteria: Compliant

I-13 Red List:

LBC Red List Free % Disclosed: 99.99% at 100ppm
 LBC Red List Approved VOC Content: Not Applicable
 Declared

I-10 Interior Performance: Not Applicable

I-14 Responsible Sourcing: Not Applicable

KOR-0001
EXP 01 OCT 2026
Original Issue Date: 2018

FOR MORE DETAILS RESPONSIBLE FOR LABEL ACCURACY
INTERNATIONAL LIVING FUTURE INSTITUTE™ living-future.org/declare

 **NZGBC**
TE KAUNIHERA HANGANGA TAUTAIAO
Member 2025–2026

 **EPD**®
AUSTRALASIA
ENVIRONMENTAL PRODUCT DECLARATION





22 Norris Ave
PO Box 20182
Te Rapa, Hamilton
0800 773 777
www.korok.com